

# Copper Plate Water Cooled Brake

Reinforced neoprene *airtube* is inherently corrosion resistant, reacts accurately to small pressure changes and offers no resistance to movement. Ensures performance without expensive and complicated control packages.

Airtube actuator heads can be retrofitted into piston powerhead packages where actuation problems exist or there is difficulty in operating over wider range torque requirements.

Friction discs are designed with specific attention to the coefficient and heat requirements needed to obtain the longest life and operating conditions of each application.

Copper plates provide rapid transfer of heat from the friction surfaces providing good control and longer life.

Hard, corrosion resistant hub coating.

O-rings are high-temp silicone allowing for expansion and contraction of copper while heat is dissipated. Eliminates "wait-time" for silicone seals to cure. (Inner & outer on each copper plate & water jacket.)

Stainless steel hardware and springs for ensured corrosion protection and smooth brake responsiveness.

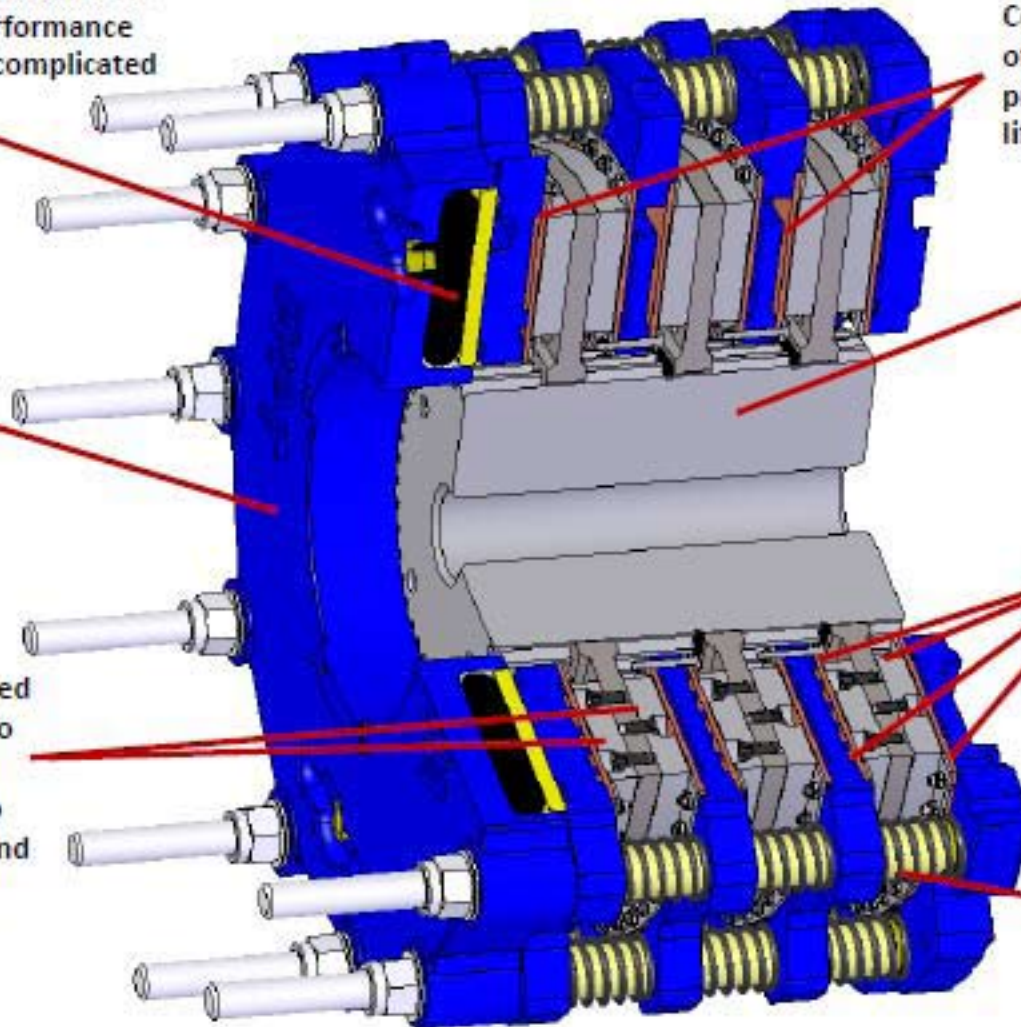

- Traceable critical path components available
- Marine corrosion protection available
- Marine certifications available



INDUSTRIAL CLUTCH PARTS LTD  
[industrialclutch.com](http://industrialclutch.com)