

TOLLOK®

Locking Assemblies



Leader in safety

Locking assemblies

TLK110

Pag. 6

Self-centering
Medium-high torque
Available from 6 mm to 130 mm diameter
Restricted radial encumbrance

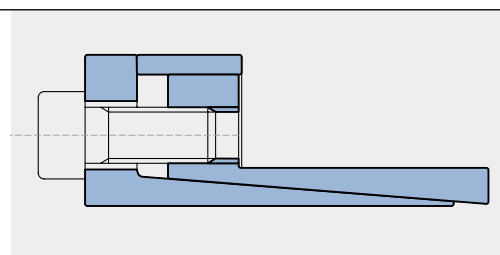

TLK130

Pag. 8

Self-centering
High torque
Available from 20 mm to 180 mm diameter
Quick installation time

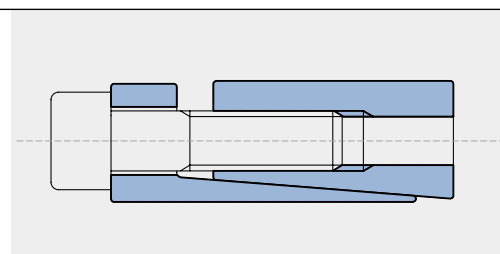

TLK131

Pag. 8

Self-centering
Medium torque
Available from 20 mm to 180 mm diameter
Low surface pressures

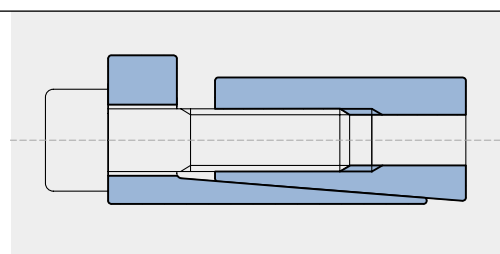

TLK132/139

Pag. 10 / Pag. 13

Self-centering
Medium-high torque
TLK 132: Available from 20 mm to 200 mm diameter
TLK 139: Available from 18 mm to 90 mm diameter

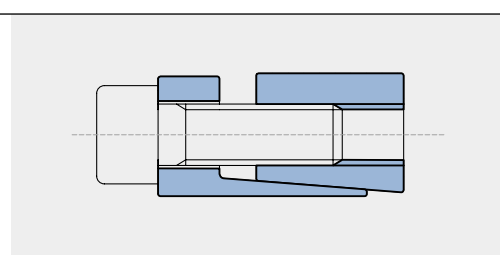

TLK133/134

Pag. 10 / Pag. 12

Self-centering
Medium torque
TLK 133: Available from 20 mm to 200 mm diameter
TLK 134: Available from 14 mm to 50 mm diameter

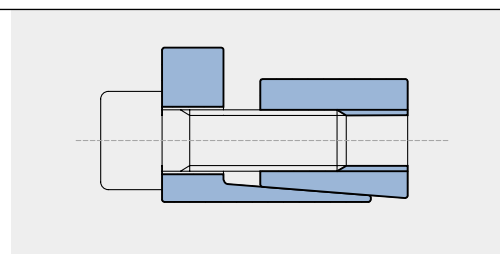

TLK200

Pag. 14

Not self-centering
Medium torque
Available from 20 mm to 900 mm diameter
Self dismantling

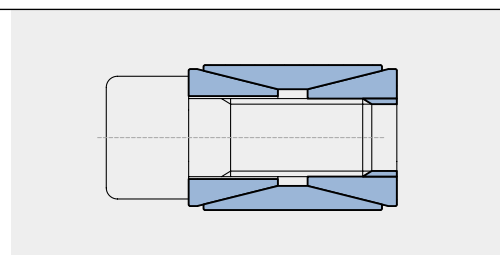

TLK250/250L

Pag. 16

Low torque
Available from 14 mm to 70 mm diameter
TLK 250: not self-centering
TLK 250L: self-centering

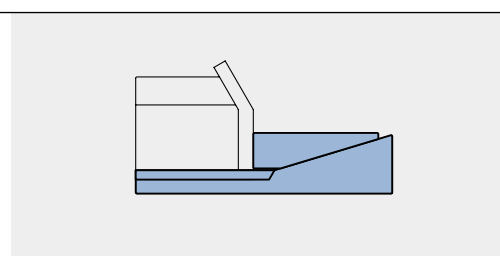

Locking assemblies

TLK300

Pag. 18

Not self-centering
Low torque
Available from 6 mm to 600 mm diameter
Restricted radial encumbrance

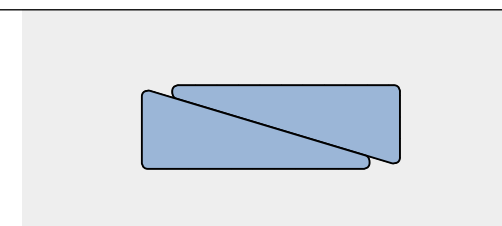

TLK350

Pag. 20

Self-centering
Medium-high torque
Available from 6 mm to 50 mm diameter
Restricted radial encumbrance

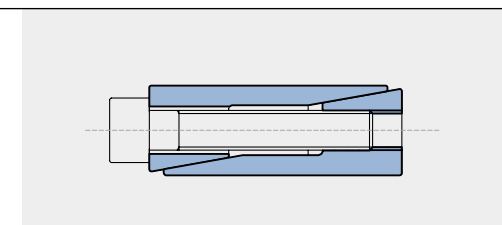

TLK400/401

Pag. 21

Self-centering
Very high torque
Available from 45 mm to 400 mm diameter
Even pressures distribution

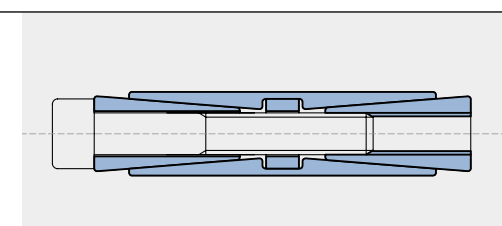

TLK450/451

Pag. 24

Self-centering
Very high torque
Available from 25 mm to 600 mm diameter
Application economically advantageous

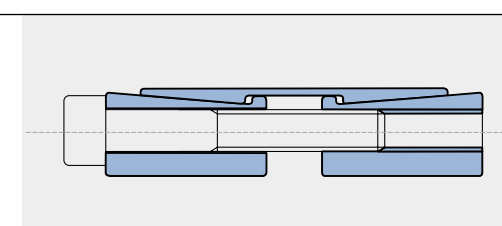

Shrink discs

TLK500

Pag. 27

Rigid coupling
Medium torque
Available from 17 mm to 80 mm diameter
Quick installation and dismantling

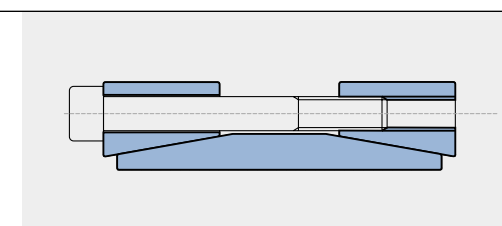

TLK601/602/603

Pag. 28

Self-centering
High / very high torque
Available from 14 mm to 480 mm diameter
Quick installation time

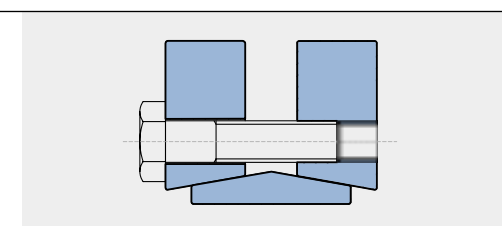

TLK622/623/681/683

Pag. 34

Self-centering
High / very high torque
Available from 12 mm to 620 mm diameter
Quick installation time

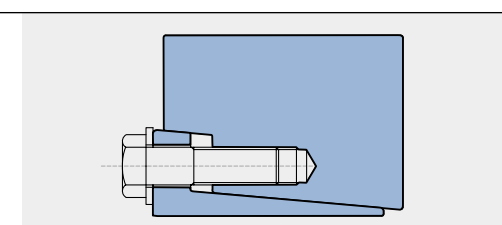

Locking assemblies

Application examples

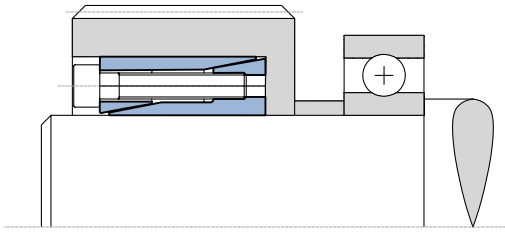

EA01

Bearing axial fastening and gear locking by means of model TLK 350

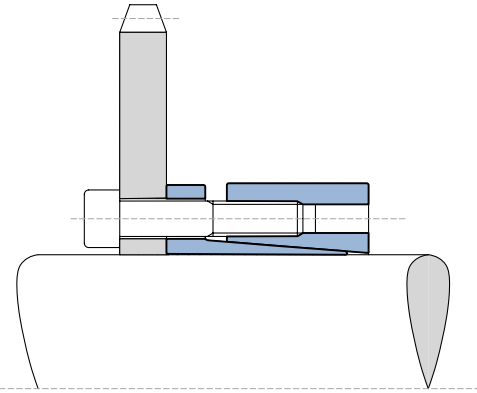

EA02

Chain sprocket locking by means of model TLK 130 with no split outside ring

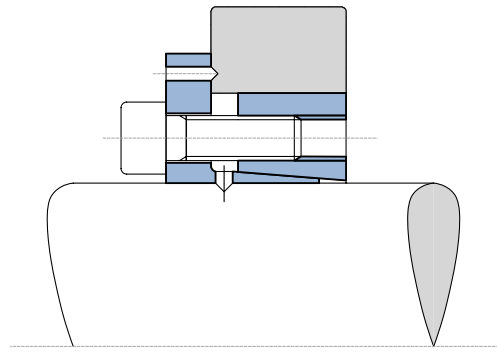

EA07

Cam locking by means of special model TLK 133

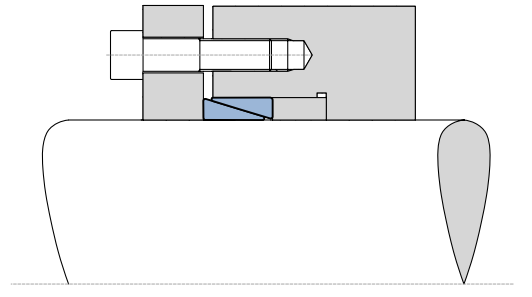

EA08

Use of model TLK 300 without spacer

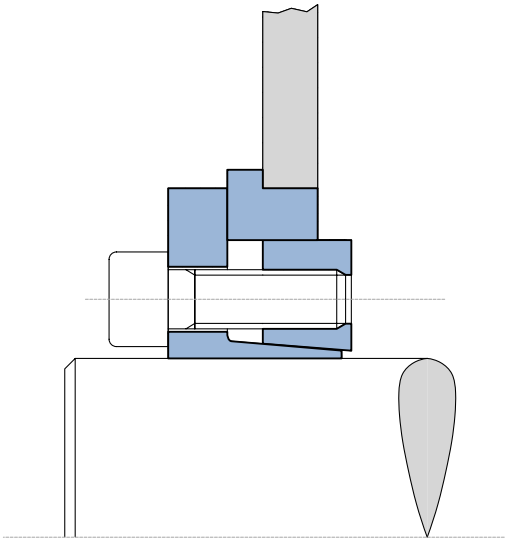

EA03

Thin plate locking by means of model TLK 133 with adapter ring

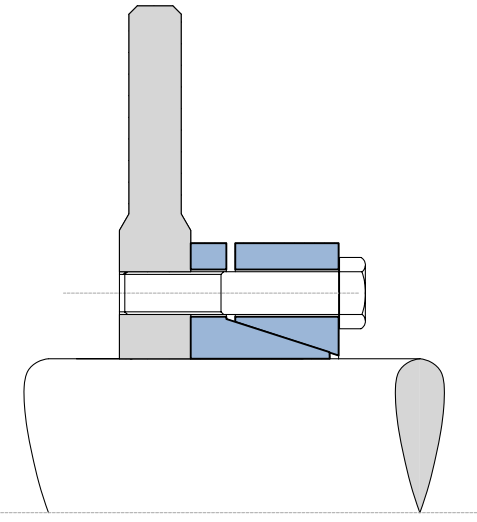

EA04

Break disc locking by means of special model TLK 700

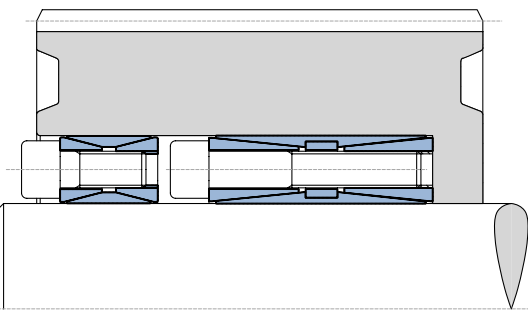

EA09

Use of several locking assemblies in presence of very heavy torque

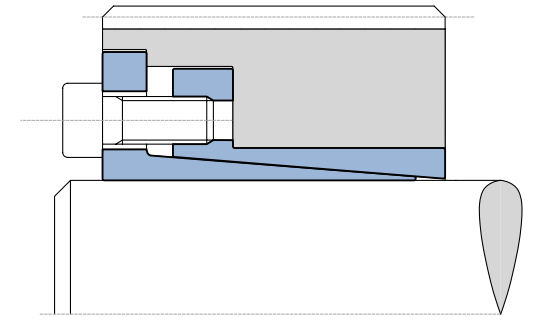

EA10

Use of model TLK 110 in presence of high rpm

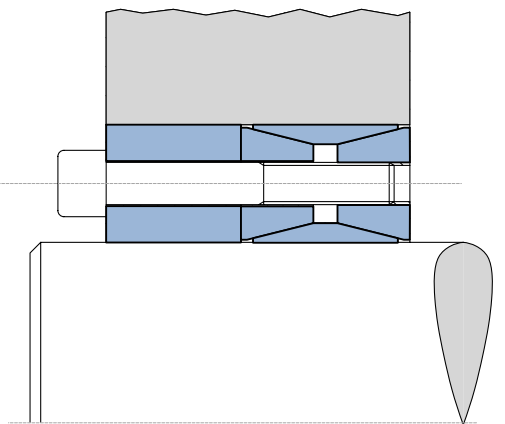

EA05

Hub locking by means of model TLK 200 with a special centering ring

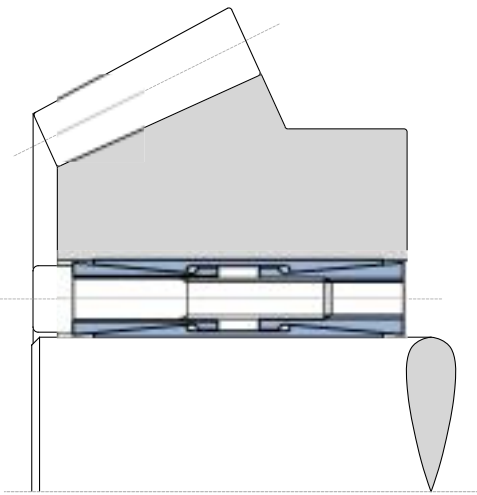

EA06

Large hub locking by means of special version of model TLK 400

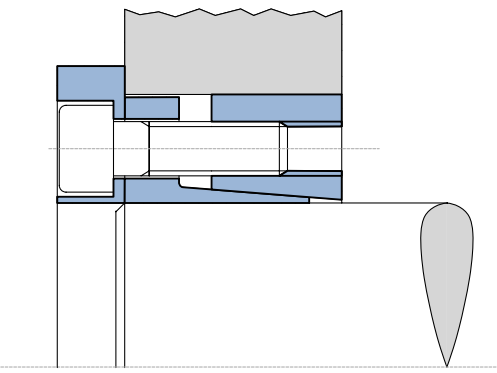

EA11

Special version of model TLK 132 with screws protection ring

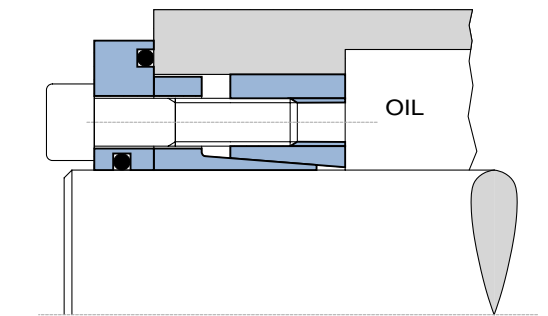

EA12

Special version of model TLK 132 with retaining ring

Locking assemblies

Application examples

Locking assembly self-centering TLK 110

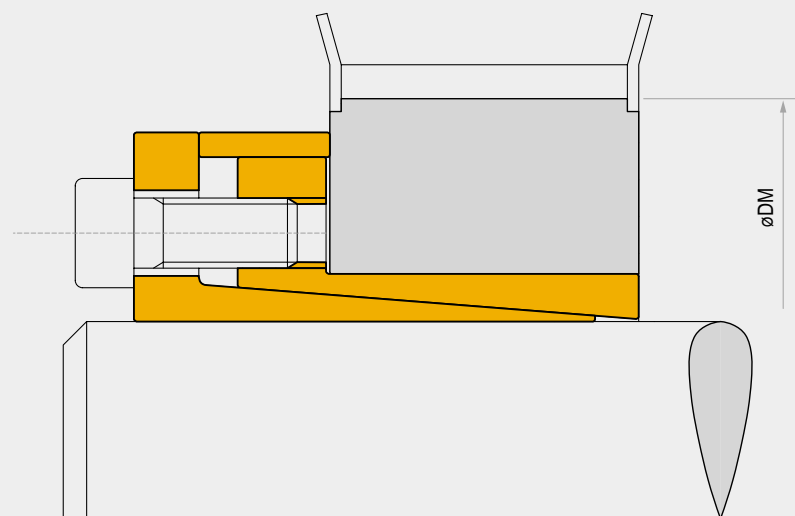

TLK 110

Characteristics

- Medium-high torque
- Restricted hub diameter
- Limited installation time
- Very low surface pressure

Installation

Carefully clean the hub and shaft contact surfaces and apply a light oil film. Slide the locking assembly into the hub bore, insert the shaft and tighten all screws gradually and regularly in crossed sequence to reach the tightening torque **Ms** as indicated in the table.

The values **Mt** and **F ass** indicated in the table are valid only in case of oil installation. Do not use any oil with **molibdenum bisulphide** or high pressure additives and not grease. Above substances notably reduce the friction coefficient.

Dismantling

Loosen the clamping screws. Insert the screws into the dismantling threading and tighten gradually and regularly in crossed sequence until the bottom cone is released. If the element is to be reused, relubricate both screws and threadings.

Tolerances, surface finish

A good surface finish by machine tool is sufficient. Maximum allowable surface finish:

$$Rt \text{ max } 16 \mu\text{m} \text{ (Ra } 3 \mu\text{m} - Rz 13 \mu\text{m)}$$

Maximum permissible tolerances:
h8 for shaft
H8 for hub

Axial movement

TLK 110: during screws tightening the hub has no axial movement with respect to the shaft.

DM hub calculation

The pressure **Pn** in the hub can be compared to the inside pressure on a thick hollow cylinder.

For DM calculation see page 38.

Locking assembly self-centering TLK 110

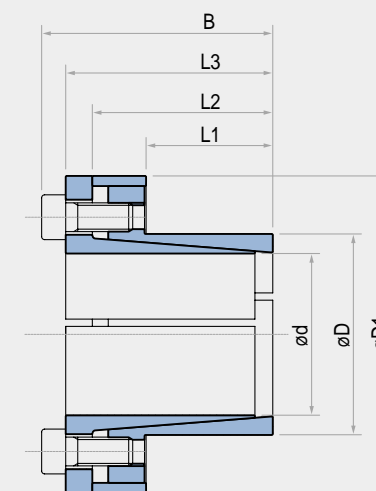

TLK 110

dxD mm	L1 mm	L2 mm	L3 mm	B mm	D1 mm	Torque Mt Nm	Axial Thrust F ass. KN	Surface pressures on		Tightening screws		Weight Kg
								Shaft pw N/mm ²	Hub pn N/mm ²	DIN 912 12.9 N° x type	Tightening torque Ms Nm	
6 x 14	10	18,5	21	24	25	12	4	185	80	3 x M3	2	0,04
7 x 15	12	22	25	29	27	25	7	235	110	3 x M4	5	0,06
8 x 15	12	22	25	29	27	29	7	205	110	3 x M4	5	0,05
9 x 16	14	23	26	30	28	44	10	205	115	4 x M4	5	0,06
10 x 16	14	23	26	30	28	49	10	185	115	4 x M4	5	0,06
11 x 18	14	23	26	30	32	53	10	170	105	4 x M4	5	0,07
12 x 18	14	23	26	30	32	58	10	160	105	4 x M4	5	0,07
13 x 23	14	23	26	30	38	63	10	140	80	4 x M4	5	0,11
14 x 23	14	23	26	30	38	68	10	130	80	4 x M4	5	0,10
* 15 x 23	14	24	30	35	39	120	16	205	135	4 x M5	10	0,14
15 x 24	16	29	36	42	45	127	17	185	115	3 x M6	17	0,22
16 x 24	16	29	36	42	45	136	17	175	115	3 x M6	17	0,22
17 x 26	18	31	38	44	47	180	22	190	125	4 x M6	17	0,25
18 x 26	18	31	38	44	47	200	22	180	125	4 x M6	17	0,24
19 x 27	18	31	38	44	49	210	22	170	120	4 x M6	17	0,26
* 19 x 28	18	31	38	43	49	150	16	125	85	4 x M5	10	0,27
20 x 28	18	31	38	44	50	220	22	160	115	4 x M6	17	0,27
22 x 32	25	38	45	51	54	250	22	115	80	4 x M6	17	0,34
24 x 34	25	38	45	51	56	270	22	105	75	4 x M6	17	0,36
25 x 34	25	38	45	51	56	280	22	100	75	4 x M6	17	0,35
28 x 39	25	38	45	51	61	465	33	135	97	6 x M6	17	0,48
30 x 41	25	38	45	51	62	510	33	127	90	6 x M6	17	0,48
32 x 43	25	38	45	51	65	540	33	120	90	6 x M6	17	0,47
35 x 47	32	45	52	58	69	790	45	105	80	8 x M6	17	0,58
38 x 50	32	45	52	58	72	860	45	100	75	8 x M6	17	0,61
40 x 53	32	45	52	58	75	900	45	95	70	8 x M6	17	0,68
42 x 55	32	45	52	58	78	950	45	90	70	8 x M6	17	0,76
45 x 59	45	62	70	78	86	1890	84	110	85	8 x M8	41	1,2
48 x 62	45	62	70	78	87	2010	84	105	80	8 x M8	41	1,2
50 x 65	45	62	70	78	92	2100	84	100	75	8 x M8	41	1,4
55 x 71	55	72	80	88	98	2600	94	85	65	9 x M8	41	1,6
60 x 77	55	72	80	88	104	2840	94	75	60	9 x M8	41	1,8
65 x 84	55	72	80	88	111	3070	94	70	55	9 x M8	41	2,1
70 x 90	65	86	96	106	119	5250	150	90	70	9 x M10	83	3,0
75 x 95	65	86	96	106	126	5600	150	80	65	9 x M10	83	3,0
80 x 100	65	86	96	106	131	8020	200	100	80	12 x M10	83	3,5
85 x 106	65	86	96	106	137	8500	200	95	75	12 x M10	83	3,6
90 x 112	65	86	96	106	144	9000	200	90	75	12 x M10	83	3,9
95 x 120	65	86	96	106	149	11000	230	100	80	14 x M10	83	4,4
100 x 125	65	86	96	106	154	15000	300	120	95	18 x M10	83	4,6
110 x 140	90	114	128	140	180	16000	290	80	65	12 x M12	145	8,7
120 x 155	90	114	128	140	198	17500	290	70	55	12 x M12	145	10,6
130 x 165	90	114	128	140	208	25000	384	90	70	16 x M12	145	11,3

For larger diameter please contact us. * upon request

Locking assemblies self-centering TLK 130 • TLK 131

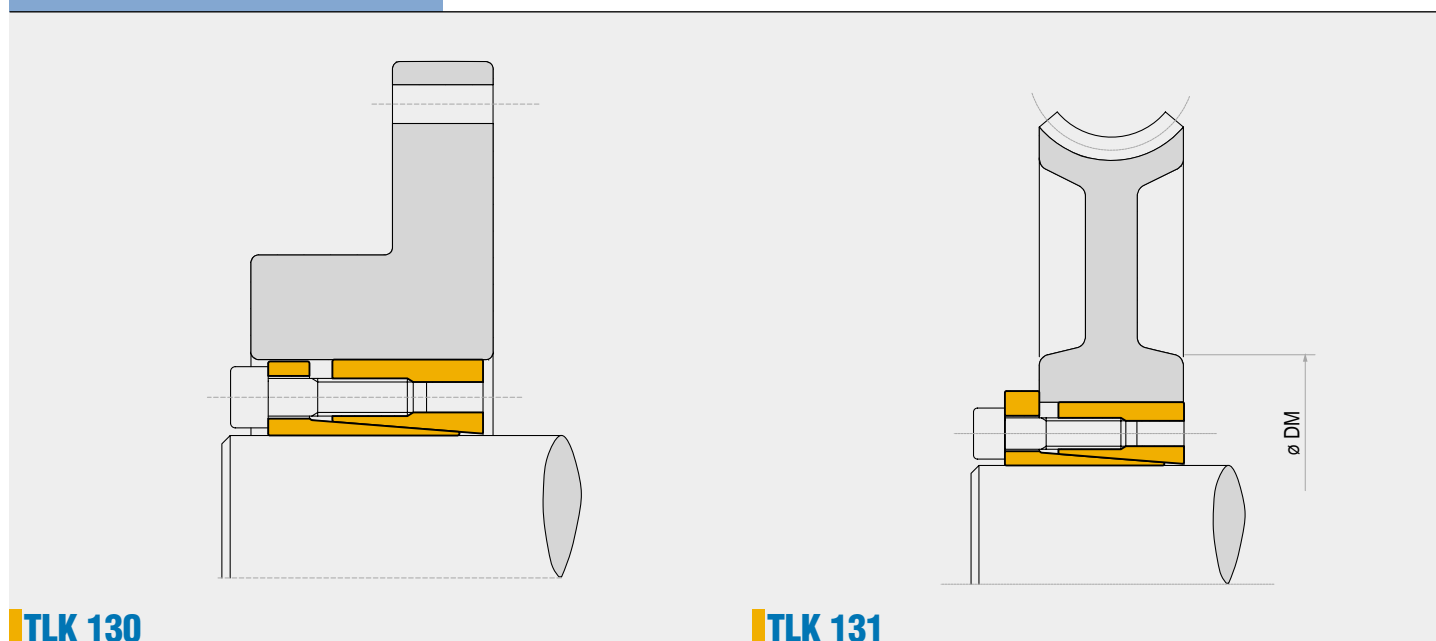

TLK 130

TLK 131

Characteristics

- High torque
- Application economically advantageous
- Limited installation time
- Excellent shaft-hub perpendicularity

Installation

Carefully clean the hub and shaft contact surfaces and apply a light oil film. Slide the locking assembly into the hub bore, insert the shaft and tighten gradually and regularly in crossed sequence all screws to reach the tightening torque **Ms** as indicated in the table.

The values **Mt** and **F ass** indicated in the table are valid only in case of oil installation. Do not use any oil with **molibdenum bisulphide** or high pressure additives and not grease. Above substances notably reduce the friction coefficient.

Dismantling

Loosen the clamping screws. Insert the screws into the dismantling threading and tighten gradually and regularly in crossed sequence until the back cone is released. If the element is to be reused, relubricate both screws and threads.

Tolerances, surface finish

A good surface finish by the machine tool is sufficient. Maximum allowable surface finish:
Rt max 16 µm (Ra 3 µm - Rz 13 µm)

Maximum permissible tolerances:
h8 for shaft
H8 for hub

Axial movement

TLK 130: during screws tightening the hub has a slight axial movement with respect to the shaft.

TLK 131: during screws tightening the hub has no axial movement with respect to the shaft.

DM hub calculation

The pressure **Pn** in the hub can be compared to the inside pressure on a thick hollow cylinder.

For DM calculation see page 38.

Locking assemblies self-centering TLK 130 • TLK 131

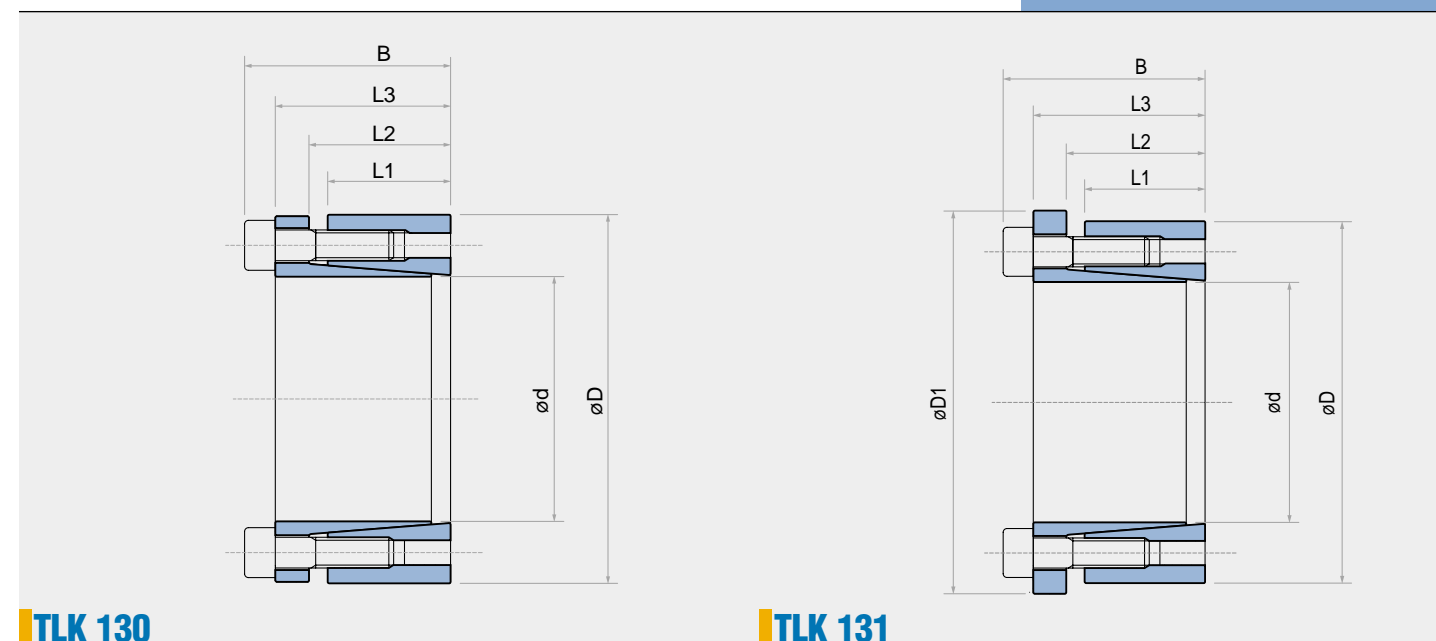

TLK 130

TLK 131

TLK 130

TLK 131

dxD mm	L1 mm	L2 mm	L3 mm	B mm	D1 mm	Tightening screws		Torque Mt Nm	Axial Thrust F ass. KN	Surface pressures on		Weight Kg	Torque Mt Nm	Axial Thrust F ass. KN	Surface pressures on		Weight Kg
						DIN 912 12.9	Tightening torque Ms Nm			Shaft pw N/mm ²	Hub pn N/mm ²				Shaft pw N/mm ²	Hub pn N/mm ²	
20 x 47	26	30	41	47	53	6 x M6	17	540	54	280	120	0,4	330	34	175	75	0,5
22 x 47	26	30	41	47	53	6 x M6	17	600	54	255	120	0,4	370	34	160	75	0,5
24 x 50	26	30	41	47	56	6 x M6	17	650	54	235	115	0,4	400	34	145	70	0,5
25 x 50	26	30	41	47	56	6 x M6	17	680	54	225	115	0,4	420	34	140	70	0,5
28 x 55	26	30	41	47	61	6 x M6	17	760	54	200	105	0,5	470	34	125	65	0,6
30 x 55	26	30	41	47	61	6 x M6	17	820	54	185	105	0,5	510	34	115	65	0,6
32 x 60	26	30	41	47	66	8 x M6	17	1160	73	235	125	0,6	720	45	145	80	0,7
35 x 60	26	30	41	47	66	8 x M6	17	1270	73	215	125	0,5	790	45	135	80	0,6
38 x 65	26	30	41	47	71	8 x M6	17	1380	73	200	115	0,6	860	45	125	70	0,8
40 x 65	26	30	41	47	71	8 x M6	17	1450	73	190	115	0,6	900	45	120	70	0,6
42 x 75	30	35	49	57	81	6 x M8	41	2130	101	215	120	1	1320	63	135	75	1,2
45 x 75	30	35	49	57	81	6 x M8	41	2280	101	200	120	1	1410	63	125	75	1,1
48 x 80	30	35	49	57	86	6 x M8	41	2430	101	190	115	1,1	1510	63	120	70	1,3
50 x 80	30	35	49	57	86	6 x M8	41	2530	101	180	115	1	1570	63	110	70	1,1
55 x 85	30	35	49	57	91	8 x M8	41	3700	135	220	140	1,1	2310	84	135	90	1,2
60 x 90	30	35	49	57	96	8 x M8	41	4000	135	200	135	1,2	2520	84	124	85	1,3
65 x 95	30	35	49	57	102	8 x M8	41	4380	135	185	125	1,3	2730	84	115	80	1,4
70 x 110	40	45	59	69	117	8 x M10	83	7500	214	205	130	2,2	4650	133	125	80	2,5
75 x 115	40	45	59	69	122	8 x M10	83	8000	214	190	125	2,5	5000	133	120	80	2,6
80 x 120	40	45	59	69	127	8 x M10	83	8560	214	180	120	2,6	5330	133	110	75	2,8
85 x 125	40	45	59	69	132	10 x M10	83	11370	268	210	145	2,8	7080	167	130	90	2,8
90 x 130	40	45	59	69	137	10 x M10	83	12000	268	200	135	2,7	7500	167	125	85	3
95 x 135	40	45	59	69	142	10 x M10	83	12600	268	190	130	2,9	7900	167	115	85	3
100 x 145	46	52	68	80	153	8 x M12	145	15580	312	180	125	3,9	9700	194	115	80	5,5
110 x 155	46	52	68	80	163	8 x M12	145	17100	312	165	115	4,2	10650	194	100	75	4,8
120 x 165	46	52	68	80	173	10 x M12	145	23370	390	190	135	4,8	14550	243	120	85	5,5
130 x 180	46	52	68	80	188	12 x M12	145	30380	467	210	150	5	18950	291	130	95	6
140 x 190	50	57	76	90	199	8 x M14	230	29900	428	165	120	6,5	18650	267	100	75	7,5
150 x 200	50	57	76	90	209	10 x M14	230	40000	535	190	145	7	25000	333	120	90	7,7
160 x 210	50	57	76	90	219	10 x M14	230	42750	535	180	135	7	26650	333	110	85	8
170 x 225	50	57	76	90	234	12 x M14	230	54500	641	200	150	8,5	34000	400	125	95	9,8
180 x 235	50	57	76	90	244	12 x M14	230	57700	641	190	145	9	36000	400	120	90	9,8

For larger diameter or inch series please contact us.

NOTE: it is possible to reduce the screws tightening torque down to 60% of the values indicated in above table; as a result **Mt**, **F ass**, **Pw**, **Pn** are reduced proportionally.

Locking assemblies self-centering TLK 132 • TLK 133

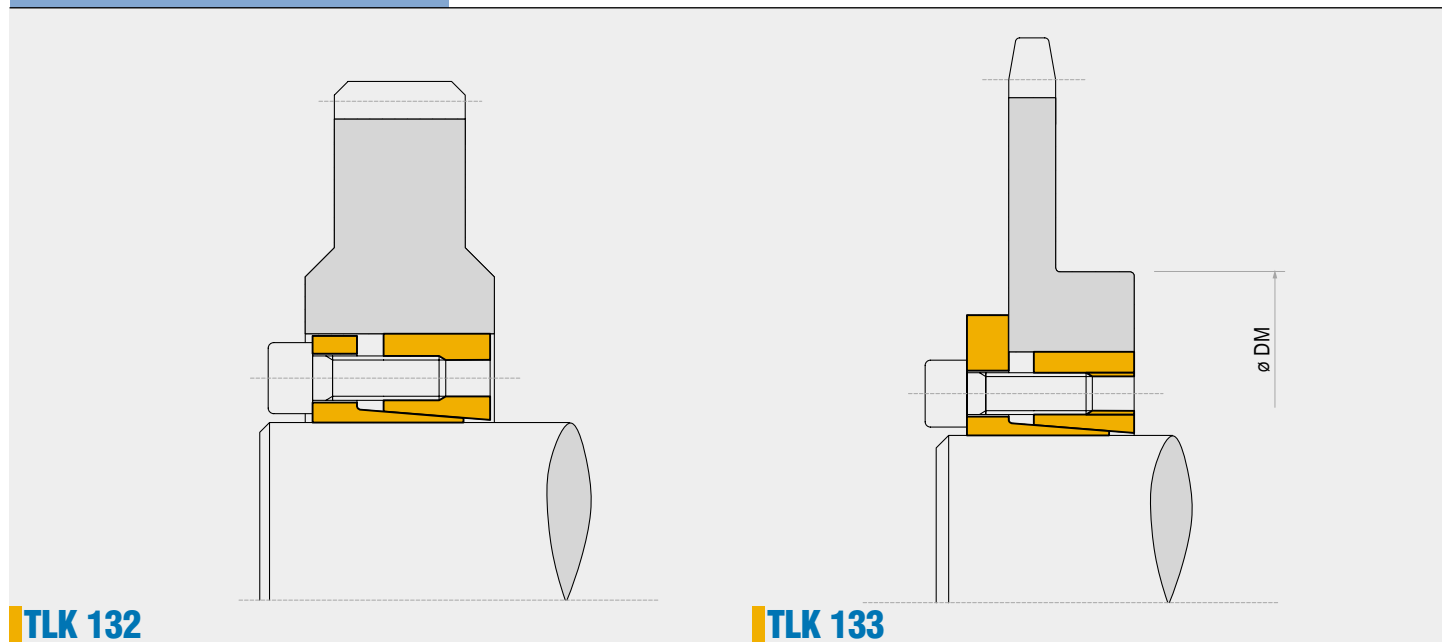

TLK 132

TLK 133

Characteristics

- Medium-high torque
- Application economically advantageous
- Limited installation time
- Interchangeable with TLK 200

Installation

Carefully clean the hub and shaft contact surfaces and apply a light oil film. Slide the locking assembly into the hub bore, insert the shaft and tighten gradually and regularly in crossed sequence all screws to reach the tightening torque **Ms** as indicated in the table.

The values **Mt** and **F ass** indicated in the table are valid only in case of oil installation. Do not use any oil with **molibdenum bisulphide** or high pressure additives and not grease. Above substances notably reduce the friction coefficient.

Dismantling

Loosen the clamping screws. Insert the screws into the dismantling threading and tighten gradually and regularly in crossed sequence until the back cone is released. If the element is to be reused, relubricate both screws and threads.

Tolerances, surface finish

A good surface finish by the machine tool is sufficient. Maximum allowable surface finish:
Rt max 16 µm (Ra 3 µm - Rz 13 µm)

Maximum permissible tolerances:
h8 for shaft
H8 for hub

Axial movement

TLK 132: during screws tightening the hub has a slight axial movement with respect to the shaft.

TLK 133: during screws tightening the hub has no axial movement with respect to the shaft.

DM hub calculation

The pressure **Pn** in the hub can be compared to the inside pressure on a thick hollow cylinder.

For DM calculation see page 38.

Locking assemblies self-centering TLK 132 • TLK 133

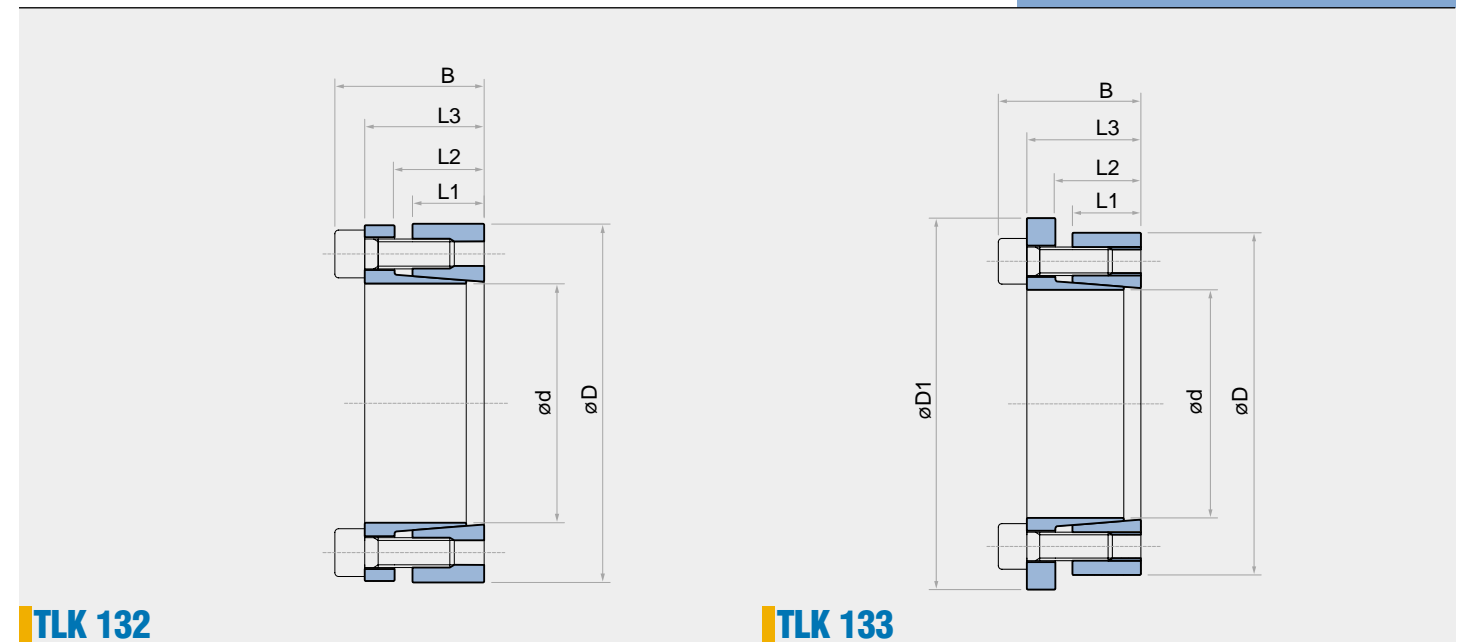

TLK 132

TLK 133

		TLK 132										TLK 133						
dxD mm	L1 mm	L2 mm	L3 mm	B mm	D1 mm	Tightening screws		Torque Mt Nm	Axial Thrust F ass. KN	Surface pressures on		Weight Kg	Torque Mt Nm	Axial Thrust F ass. KN	Surface pressures on		Weight Kg	
						DIN 912 12.9	Tightening torque			Shaft	Hub				Shaft	Hub		
																		N°x type
20 x 47	17	22	28	34	54	5 x M6	14	17	380	38	295	125	0,3	280	28	220	95	0,3
22 x 47	17	22	28	34	54	5 x M6	14	17	410	38	270	125	0,3	300	28	200	95	0,3
24 x 50	17	22	28	34	57	5 x M6	14	17	450	38	245	120	0,3	330	28	180	90	0,3
25 x 50	17	22	28	34	57	6 x M6	14	17	570	46	285	140	0,3	420	34	210	105	0,3
28 x 55	17	22	28	34	62	6 x M6	14	17	630	46	255	130	0,4	470	34	190	95	0,4
30 x 55	17	22	28	34	62	6 x M6	14	17	660	46	235	130	0,3	500	34	175	95	0,4
32 x 60	17	22	28	34	67	8 x M6	14	17	970	60	295	155	0,4	720	45	220	115	0,4
35 x 60	17	22	28	34	67	8 x M6	14	17	1060	60	270	155	0,4	790	45	200	115	0,4
38 x 65	17	22	28	34	72	8 x M6	14	17	1150	60	250	145	0,4	850	45	185	105	0,5
40 x 65	17	22	28	34	72	8 x M6	14	17	1210	60	235	145	0,4	900	45	175	105	0,5
42 x 75	20	25	33	41	82	7 x M8	35	41	2050	98	300	170	0,8	1530	73	225	125	0,8
45 x 75	20	25	33	41	82	7 x M8	35	41	2200	98	290	170	0,6	1650	73	215	125	0,7
48 x 80	20	25	33	41	87	7 x M8	35	41	2350	98	270	160	0,8	1760	73	200	120	0,8
50 x 80	20	25	33	41	87	7 x M8	35	41	2450	98	260	160	0,8	1830	73	195	120	0,8
55 x 85	20	25	33	41	92	8 x M8	35	41	3080	112	270	175	0,8	2300	83	200	130	0,9
60 x 90	20	25	33	41	97	8 x M8	35	41	3360	112	245	165	0,8	2510	83	185	125	0,9
65 x 95	20	25	33	41	102	9 x M8	35	41	4090	126	255	175	0,9	3060	94	190	130	1
70 x 110	24	30	40	50	117	8 x M10	70	83	6300	179	280	180	1,8	4670	133	210	135	1,9
75 x 115	24	30	40	50	122	8 x M10	70	83	6700	179	260	170	1,8	5000	133	195	125	2
80 x 120	24	30	40	50	127	8 x M10	70	83	7150	179	250	170	1,8	5300	133	185	125	2
85 x 125	24	30	40	50	132	9 x M10	70	83	8500	200	260	180	2	6300	148	195	135	2
90 x 130	24	30	40	50	137	9 x M10	70	83	9100	200	250	170	2,1	6750	148	185	130	2,2
95 x 135	24	30	40	50	142	10 x M10	70	83	10600	224	260	180	2,1	7900	166	195	135	2,3
100 x 145	26	32	44	56	152	8 x M12	125	145	13400	268	270	190	2,8	9700	194	200	140	3
110 x 155	26	32	44	56	162	8 x M12	125	145	14600	268	240	180	3	10600	194	180	130	3,2
120 x 165	26	32	44	56	172	9 x M12	125	145	17900	298	250	180	3,2	13000	216	185	135	3,4
130 x 180	34	40	54	66	187	12 x M12	125	145	26000	400	240	170	4,8	18900	290	175	125	5,2
140 x 190	34	40	54	68	197	9 x M14	190	230	27000	384	210	150	5,2	20500	290	165	120	5,4
150 x 200	34	40	54	68	207	10 x M14	190	230	33000	440	230	170	5,4	25000	333	175	130	5,7
160 x 210	34	40	54	68	217	11 x M14	190	230	38000	479	230	170	5,7	29000	362	180	135	6
170 x 225	44	50	64	78	232	12 x M14	190	230	45000	530	180	130	8	34000	400	140	105	8,3
180 x 235	44	50	64	78	242	12 x M14	190	230	47000	530	170	130	8,3	36000	400	135	105	8,8
190 x 250	44	50	64	78	257	15 x M14	190	230	62900	660	210	150	9,6	47500	500	160	120	10
200 x 260	44	50	64	78	267	15 x M14	190	230	66000	660	190	150	10	50000	500	150	115	10,5

For larger diameter or inch series please contact us.

NOTE: it is possible to reduce the screws tightening torque down to 60% of the values indicated in above table; as a result Mt, F ass, Pw, Pn are reduced proportionally.

Locking assembly self-centering TLK 134

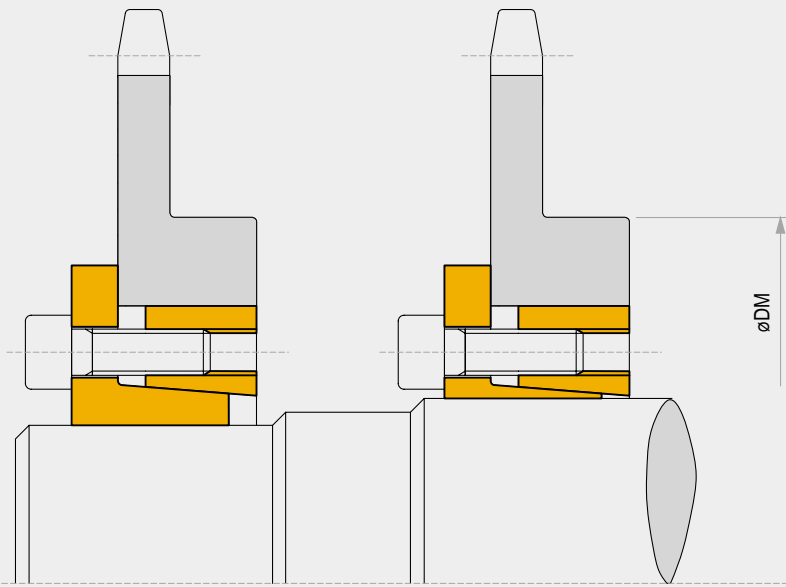

TLK 134

Characteristics

The same as TLK 133 (pag.10)

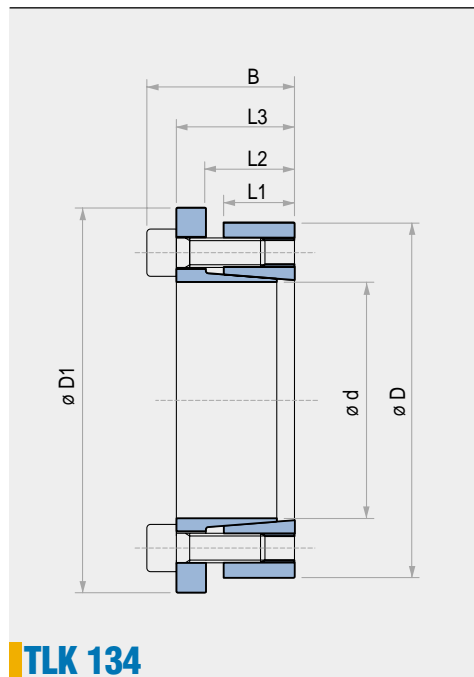

TLK 134

dxD mm	L1 mm	L2 mm	L3 mm	B mm	D1 mm	Torque Mt Nm	Axial Thrust F ass. KN	Surface pressures on		Tightening screws Tightening torque DIN 912		Weight Kg
								Shaft pw N/mm ²	Hub pn N/mm ²	12.9 N° x type	Ms Nm	
14 x 55						120	18	205	55		25	0,5
16 x 55						140	18	180	55		25	0,5
18 x 55						150	18	160	55		25	0,5
19 x 55						160	18	150	55		25	0,5
20 x 55	17	22	30	38	62	170	18	145	55	3 x M8	25	0,5
22 x 55						280	25	185	75		35	0,5
24 x 55						300	25	170	75		35	0,5
25 x 55						310	25	165	75		35	0,5
28 x 55						430	31	175	90		41	0,4
30 x 55						470	31	165	90		41	0,4
24 x 65						440	37	244	90		30	0,7
25 x 65						460	37	234	90		30	0,7
28 x 65						600	44	243	105		35	0,6
30 x 65						640	44	227	105		35	0,6
32 x 65	17	22	30	38	72	690	44	213	105	5 x M8	35	0,6
35 x 65						910	52	234	126		41	0,5
38 x 65						990	52	216	126		41	0,5
40 x 65						1050	52	205	126		41	0,5
30 x 80						780	52	232	87		30	1
32 x 80						830	52	217	87		30	1
35 x 80						1060	61	232	102		35	1
38 x 80						1150	61	214	102		35	1
40 x 80	20	25	33	41	87	1220	61	203	102	7 x M8	35	0,9
42 x 80						1540	73	233	122		41	0,9
45 x 80						1650	73	217	122		41	0,8
48 x 80						1760	73	203	122		41	0,8
50 x 80						1830	73	195	122		41	0,8

Locking assembly self-centering TLK 139

dxD mm	L1 mm	L2 mm	L3 mm	B mm	Torque Mt Nm	Axial Thrust F ass. KN	Surface pressures on		Tightening screws Tightening torque DIN 912		Weight Kg
							Shaft pw N/mm ²	Hub pn N/mm ²	12.9 N° x type	Ms Nm	
18 x 40	12	15	20	24	210	23,7	233	131	6 x M4	5	0,2
19 x 41	12	15	20	24	220	23,7	221	128	6 x M4	5	0,2
20 x 42	12	15	20	24	270	27,7	245	146	7 x M4	5	0,2
22 x 44	12	15	20	24	300	27,7	223	139	7 x M4	5	0,2
24 x 46	12	15	20	24	330	27,7	204	133	7 x M4	5	0,2
25 x 47	12	15	20	24	340	27,7	196	130	7 x M4	5	0,2
28 x 50	12	15	20	24	500	35,6	225	157	9 x M4	5	0,2
30 x 52	12	15	20	24	530	35,6	210	151	9 x M4	5	0,2
32 x 54	12	15	20	24	570	35,6	197	146	9 x M4	5	0,2
35 x 57	16	19	24	28	690	39,5	158	115	10 x M4	5	0,3
36 x 58	16	19	24	28	710	39,5	153	113	10 x M4	5	0,3
38 x 60	16	19	24	28	830	43,5	160	120	11 x M4	5	0,3
40 x 62	16	19	24	28	870	43,5	152	116	11 x M4	5	0,4
42 x 70	19	23	30	36	1530	73	200	146	8 x M6	17	0,6
45 x 73	19	23	30	36	1640	73	187	140	8 x M6	17	0,6
48 x 76	19	23	30	36	1750	73	175	134	8 x M6	17	0,6
50 x 78	19	23	30	36	1820	73	168	131	8 x M6	17	0,6
55 x 83	19	23	30	36	2000	73	153	123	8 x M6	17	0,7
56 x 84	19	23	30	36	2040	73	150	121	8 x M6	17	0,7
60 x 88	19	23	30	36	2460	82,1	158	130	9 x M6	17	0,7
63 x 91	19	23	30	36	2580	82,1	150	126	9 x M6	17	0,9
65 x 93	19	23	30	36	2660	82,1	146	123	9 x M6	17	1
70 x 105	23	28	37	45	4720	134,8	183	148	8 x M8	41	1,5
75 x 110	23	28	37	45	5050	134,8	170	141	8 x M8	41	1,5
80 x 115	23	28	37	45	5390	134,8	160	135	8 x M8	41	1,7
85 x 120	23	28	37	45	5730	134,8	150	130	8 x M8	41	2
90 x 125	23	28	37	45	7580	168,5	177	156	10 x M8	41	2,3

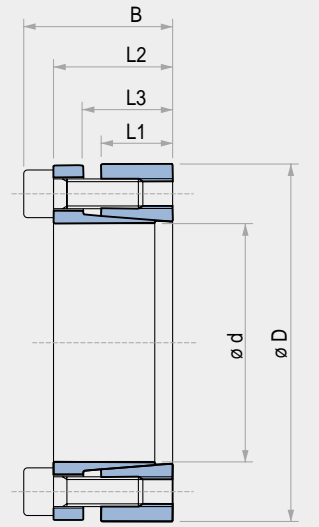

TLK 139

Characteristics

- Medium-low torque
- Limited installation time
- Application economically advantageous

Installation

Carefully clean the hub and shaft contact surfaces and apply a light oil film. Slide the locking assembly into the hub bore, insert the shaft and tighten gradually and regularly in crossed sequence all screws to reach the tightening torque **Ms** as indicated in the table. The values **Mt** and **F ass** indicated in the table are valid only in case of oil installation. Do not use any oil with **molibdenum bisulphide** or high pressure additives and not grease. Above substances notably reduce the friction coefficient.

Dismantling

Loosen the clamping screws. Insert the screws into the dismantling threading and tighten gradually and regularly in crossed sequence till the back cone is released. If the element is to be reused, relubricate both screws and threads.

Tolerances, surface finish

A good surface finish by machine tool is sufficient. Maximum allowable surface finish:
Rt max 16 µm (Ra 3 µm - Rz 13 µm)

Maximum permissible tolerances:
h8 for shaft
H8 for hub

Axial movement

TLK 139: during screws tightening the hub has a slight axial movement with respect to the shaft.

DM hub calculation

The pressure **Pn** in the hub can be compared to the inside pressure on a thick hollow cylinder.

For DM calculation see page 38.

Locking assembly not self-centering TLK 200

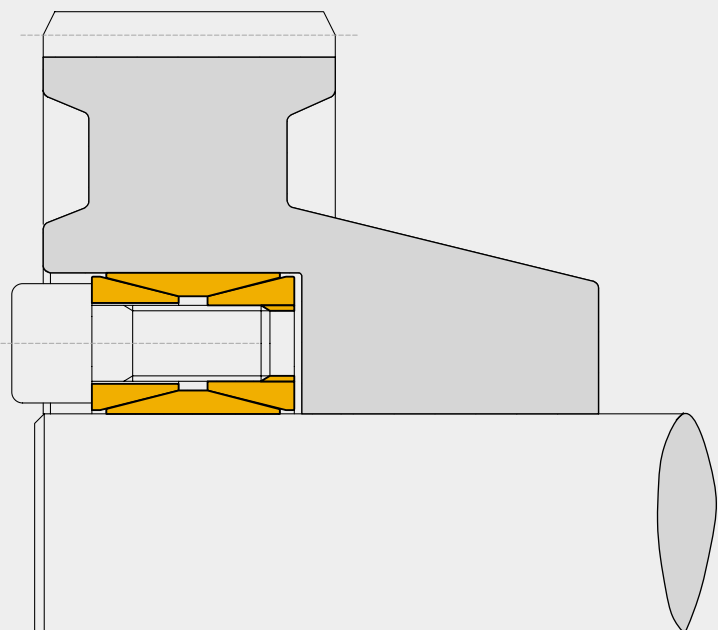

TLK 200

Characteristics

- Medium-high torque
- Wide tolerances
- Easy availability
- Easy dismantling

Installation

Carefully clean the hub and shaft contact surfaces and apply a light oil film. Slide the locking assembly into the hub bore and insert the shaft. Tighten cadmium plated clamping screws until inner ring grips the shaft and the outer ring grips the hub bore then tighten gradually and regularly in crossed sequence all screws to reach the tightening torque **Ms** indicated in the table. The values **Mt** and **F ass** indicated in the table are valid only in case of oil installation. Do not use any oil with **molibdenum bisulphide** or high pressure additives and not grease.

Dismantling

By loosening all tightening screws the clamping unit is normally released. In case of difficulties slightly hammer the released screws to push back the rear pressure cone.

Tolerances, surface finish

A good surface finish by machine tool is sufficient. Maximum allowable surface finish:
Rt max 16 µm (Ra 3 µm - Rz 13 µm)
 Maximum permissible tolerances:
h11 for shaft
H11 for hub

Centering

Mod. TLK 200 is not self-centering. The hub concentricity with respect to the shaft depends on the guide surface tolerance and its length.

Axial movement

TLK 200: during screws tightening the hub has no axial movement with respect to the shaft.

DM hub calculation

The pressure **Pn** on the hub can be compared to the inside pressure on a thick hollow cylinder.

For DM calculation see page 38.

Mt transmissible

If two or more clamping unit are installed together, as a result of carried tests, the **Mt** transmissible shall be calculated as follow:

- Nr. 1 TLK 200** **Mt = Mt cat.**
- Nr. 2 TLK 200** **Mt = Mt cat. • 1,9**
- Nr. 3 TLK 200** **Mt = Mt cat. • 2,7**

Locking assembly not self-centering TLK 200

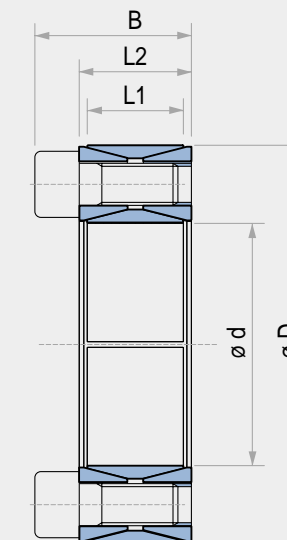

TLK 200

dxD mm	L1 mm	L2 mm	B mm	Torque		Surface pressures on		Tightening screws		Weight Kg
				Mt Nm	F ass. KN	Shaft pw N/mm ²	Hub pn N/mm ²	DIN 912	Tightening torque Ms Nm	
20 x 47	17	20	27,5	280	29	225	95	8 x M6	15	0,2
22 x 47	17	20	27,5	310	29	210	95	8 x M6	15	0,2
24 x 50	17	20	27,5	370	32	210	100	8 x M6	15	0,3
25 x 50	17	20	27,5	400	32	200	100	8 x M6	15	0,3
28 x 55	17	20	27,5	500	36	200	100	10 x M6	15	0,3
30 x 55	17	20	27,5	530	36	185	100	10 x M6	15	0,3
32 x 60	17	20	27,5	680	42	205	110	12 x M6	15	0,3
35 x 60	17	20	27,5	750	43	190	110	12 x M6	15	0,3
38 x 65	17	20	27,5	930	49	200	115	14 x M6	15	0,4
40 x 65	17	20	27,5	980	49	190	115	14 x M6	15	0,3
42 x 75	20	24	33,5	1580	75	235	130	12 x M8	37	0,6
45 x 75	20	24	33,5	1700	76	220	130	12 x M8	37	0,6
48 x 80	20	24	33,5	1790	74	210	120	12 x M8	37	0,6
50 x 80	20	24	33,5	1870	75	200	120	12 x M8	37	0,6
55 x 85	20	24	33,5	2390	88	210	135	14 x M8	37	0,6
60 x 90	20	24	33,5	2610	88	190	125	14 x M8	37	0,7
65 x 95	20	24	33,5	3210	98	200	135	16 x M8	37	0,7
70 x 110	24	28	39,5	4600	132	210	130	14 x M10	70	1,3
75 x 115	24	28	39,5	4900	131	195	125	14 x M10	70	1,3
80 x 120	24	28	39,5	5200	131	180	120	14 x M10	70	1,4
85 x 125	24	28	39,5	6300	148	195	130	16 x M10	70	1,4
90 x 130	24	28	39,5	6600	147	180	125	16 x M10	70	1,5
95 x 135	24	28	39,5	7900	167	195	135	18 x M10	70	1,6
100 x 145	26	33	47	9750	195	195	135	14 x M12	127	2,2
110 x 155	26	33	47	10650	194	180	125	14 x M12	127	2,5
120 x 165	26	33	47	13300	221	185	135	16 x M12	127	2,6
130 x 180	34	38	52	17850	276	165	115	20 x M12	127	3,8
140 x 190	34	38	52	21200	302	165	125	22 x M12	127	3,9
150 x 200	34	38	52	24500	329	170	125	24 x M12	127	4
160 x 210	34	38	52	28400	355	170	130	26 x M12	127	4,3
170 x 225	38	44	60	33600	396	165	120	22 x M14	195	5,8
180 x 235	38	44	60	38700	431	170	130	24 x M14	195	6
190 x 250	46	52	68	44700	502	155	120	28 x M14	195	8,5
200 x 260	46	52	68	53500	538	155	120	30 x M14	195	8,6
220 x 285	50	56	74	68500	630	155	120	26 x M16	300	11
240 x 305	50	56	74	86000	717	165	130	30 x M16	300	12
260 x 325	50	56	74	105000	810	165	135	34 x M16	300	13
280 x 355	60	66	86,5	128500	920	150	120	32 x M18	410	19
300 x 375	60	66	86,5	153600	1025	155	125	36 x M18	410	20
320 x 405	72	78	100,5	210500	1325	155	125	36 x M20	590	30
340 x 425	72	78	100,5	225000	1325	150	120	36 x M20	590	30
360 x 455	84	90	116	294700	1635	150	120	36 x M22	790	42
380 x 475	84	90	116	309100	1625	140	120	36 x M22	790	44
400 x 495	84	90	116	321900	1617	135	110	36 x M22	790	46
420 x 515	84	90	116	374000	1780	135	110	40 x M22	790	50
440 x 545	96	102	130	455000	2060	130	105	40 x M24	1000	65
460 x 565	96	102	130	470000	2040	125	100	40 x M24	1000	67
480 x 585	96	102	130	515000	2160	125	100	42 x M24	1000	71
500 x 605	96	102	130	560000	2240	125	100	44 x M24	1000	73
520 x 630	96	102	130	600000	2320	125	100	45 x M24	1000	80
540 x 650	96	102	130	630000	2340	120	100	45 x M24	1000	82
560 x 670	96	102	130	680000	2440	120	100	48 x M24	1000	85
580 x 690	96	102	130	735000	2540	120	100	50 x M24	1000	88
600 x 710	96	102	130	775000	2580	120	100	50 x M24	1000	91
620 x 730	96	102	130	825000	2660	120	100	52 x M24	1000	93
640 x 750	96	102	130	865000	2700	115	100	54 x M24	1000	96
660 x 770	96	102	130	925000	2800	120	100	56 x M24	1000	99
680 x 790	96	102	130	965000	2840	115	100	56 x M24	1000	102
700 x 810	96	102	130	1030000	2960	115	100	60 x M24	1000	104
720 x 830	96	102	130	1070000	2980	115	100	60 x M24	1000	107
740 x 850	96	102	130	1140000	3080	115	100	62 x M24	1000	110
760 x 870	96	102	130	1210000	3180	115	100	64 x M24	1000	113
780 x 890	96	102	130	1250000	3220	115	100	65 x M24	1000	116
800 x 910	96	102	130	1300000	3260	115	100	66 x M24	1000	118
820 x 930	96	102	130	1370000	3340	115	100	68 x M24	1000	121
840 x 950	96	102	130	1450000	3460	115	100	70 x M24	1000	124
860 x 970	96	102	130	1520000	3540	115	100	72 x M24	1000	127
880 x 990	96	102	130	1590000	3620	115	100	74 x M24	1000	129
900 x 1010	96	102	130	1650000	3680	115	100	75 x M24	1000	132

For larger diameter or inch series please contact us.

Locking assemblies

TLK 250 not self-centering

TLK 250 L self-centering

Locking assembly not self-centering

TLK 250

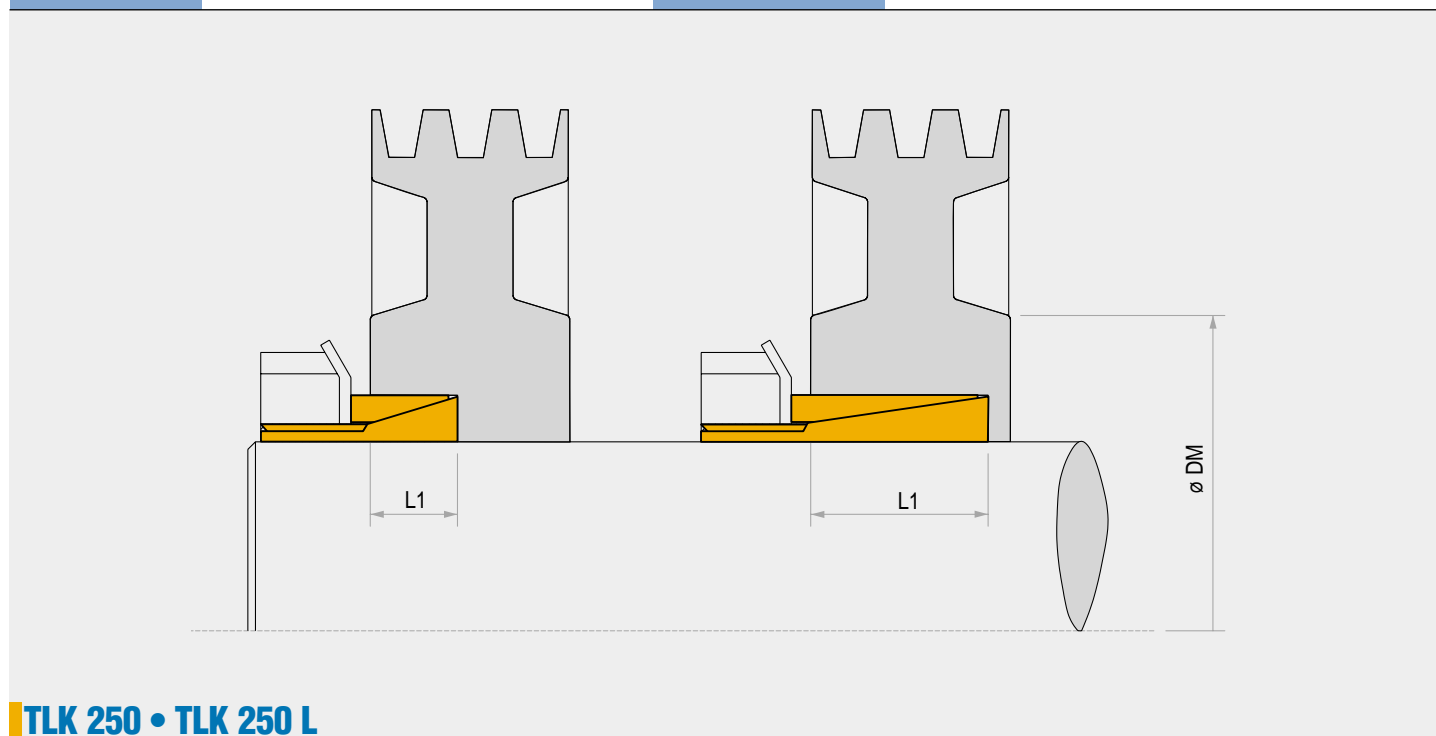

TLK 250 • TLK 250 L

dxD mm	B mm	L1 mm	D1 mm	Torque Mt Nm	Axial Thrust F ass. KN	Surface pressures on		Tightening nut Type	Tightening torque Ms Nm	Weight Kg
						Shaft pw N/mm ²	Hub pn N/mm ²			
14 x 25	16,5	6,5	32	38	5	200	110	KM4	95	0,05
15 x 25	16,5	6,5	32	41	5	185	110	KM4	95	0,05
16 x 25	16,5	6,5	32	43	5	174	110	KM4	95	0,04
17 x 30	18	6,5	38	55	6	197	112	KM5	160	0,08
18 x 30	18	6,5	38	58	6	186	112	KM5	160	0,08
19 x 30	18	6,5	38	62	7	176	112	KM5	160	0,08
20 x 30	18	6,5	38	66	7	167	111	KM5	160	0,07
22 x 35	18	6,5	45	96	8	202	127	KM6	220	0,1
24 x 35	18	6,5	45	105	9	185	127	KM6	220	0,09
25 x 35	18	6,5	45	110	9	178	127	KM6	220	0,09
28 x 40	19,5	7	52	150	10	176	123	KM7	340	0,07
30 x 40	19,5	7	52	160	11	164	123	KM7	340	0,07
32 x 45	21,5	8	58	210	12	167	120	KM8	480	0,18
35 x 45	21,5	8	58	230	13	153	120	KM8	480	0,17
36 x 45	21,5	8	58	240	13	149	120	KM8	480	0,15
38 x 52	24,5	10	65	290	14	126	93	KM9	680	0,25
40 x 52	24,5	10	65	310	15	120	93	KM9	680	0,24
42 x 57	25,5	10	70	370	17	131	96	KM10	870	0,3
45 x 57	25,5	10	70	400	18	122	96	KM10	870	0,28
48 x 62	25,5	10	75	500	21	135	105	KM11	970	0,32
50 x 62	25,5	10	75	520	21	130	105	KM11	970	0,3
55 x 68	27,5	12	80	610	22	103	84	KM12	1100	0,36
56 x 68	27,5	12	80	620	22	101	82	KM12	1100	0,34
60 x 73	28,5	12	85	800	27	113	93	KM13	1300	0,4
63 x 79	30,5	14	92	980	31	107	86	KM14	1600	0,56
65 x 79	30,5	14	92	1010	31	104	86	KM14	1600	0,52
70 x 84	31,5	14	98	1240	35	110	92	KM15	2000	0,6

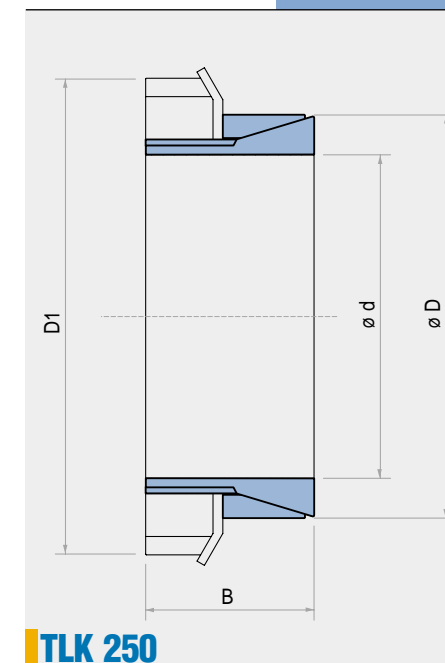

TLK 250

Characteristics

- Medium-low torque
- Restricted hub diameter
- Limited installation time
- Application economically advantageous

Tolerances, surface finish

A good surface finish by machine tool is sufficient. Maximum allowable surface finish: Rt max 16 µm (Ra 3 µm - Rz 13 µm)

Maximum permissible tolerances:
h8 for shaft
H8 for hub

Installation

Carefully clean the hub and shaft contact surfaces and apply a light oil film. Slide the locking assembly into the hub bore, insert the shaft and tighten the nut at tightening torque **Ms** as indicated in the table and fold down the security washer tooth if fitted. The values **Mt** and **F ass** indicated in the table are valid only in case of oil installation. Do not use any oil with **molybdenum bisulphide** or high pressure additives and not grease. Above substances notably reduce the friction coefficient.

Dismantling

Loosen the tightening collar. As the cone angle of TLK 250 is about 17°, the unit is self releasing. To avoid dismantling difficulties for model TLK 250 L, because of restricted angle, we recommend the use of mod. TLK 250.

Axial movement

TLK 250 + TLK 250L: during screws tightening the hub has a slight axial movement with respect to the shaft.

DM hub calculation

The pressure **Pn** in the hub can be compared to the inside pressure on a thick hollow cylinder.

For DM calculation see page 38.

Locking assembly self-centering

TLK 250 L

dxD mm	B mm	L1 mm	D1 mm	Torque Mt Nm	Axial Thrust F ass. KN	Surface pressures on		Tightening nut Type	Tightening torque Ms Nm	Weight Kg
						Shaft pw N/mm ²	Hub pn N/mm ²			
14 x 25	30	20	32	64	9	85	45	KM4	95	0,08
15 x 25	30	20	32	70	9	80	45	KM4	95	0,08
16 x 25	30	20	32	73	9	75	45	KM4	95	0,07
17 x 25	32	20	32	80	9	70	45	KM4 *	95	0,07
18 x 30	32	20	38	100	10	80	45	KM5	160	0,12
19 x 30	32	20	38	105	11	75	45	KM5	160	0,12
20 x 30	32	20	38	112	11	70	45	KM5	160	0,11
22 x 35	36	25	45	163	14	70	45	KM6	220	0,18
24 x 35	36	25	45	178	14	65	45	KM6	220	0,16
25 x 35	36	25	45	185	14	60	45	KM6	220	0,15
28 x 40	42	30	52	250	17	55	40	KM7	340	0,24
30 x 40	42	30	52	270	17	50	40	KM7	340	0,21
32 x 45	44	30	58	350	21	60	45	KM8	480	0,32
35 x 45	44	30	58	390	21	55	45	KM8	480	0,26
38 x 50	45	30	65	500	26	60	45	KM9	680	0,35
40 x 50	45	30	65	520	26	55	45	KM9	680	0,33
42 x 55	46	30	70	630	30	65	50	KM10	870	0,43
45 x 55	46	30	70	680	30	60	50	KM10	870	0,39
48 x 60	46	30	75	840	35	60	50	KM11	970	0,45
50 x 60	46	30	75	880	35	60	50	KM11	970	0,4
55 x 65	46	30	80	1030	37	60	50	KM12	1100	0,44
60 x 70	52	30	85	1360	45	65	55	KM13	1300	0,55

* Without washer

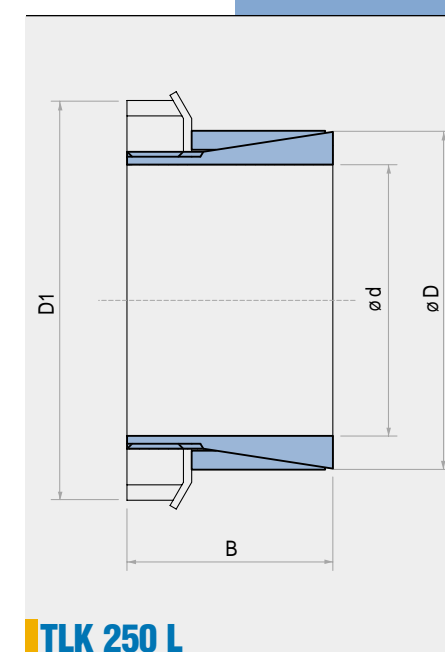

TLK 250 L

Locking elements not self-centering TLK 300

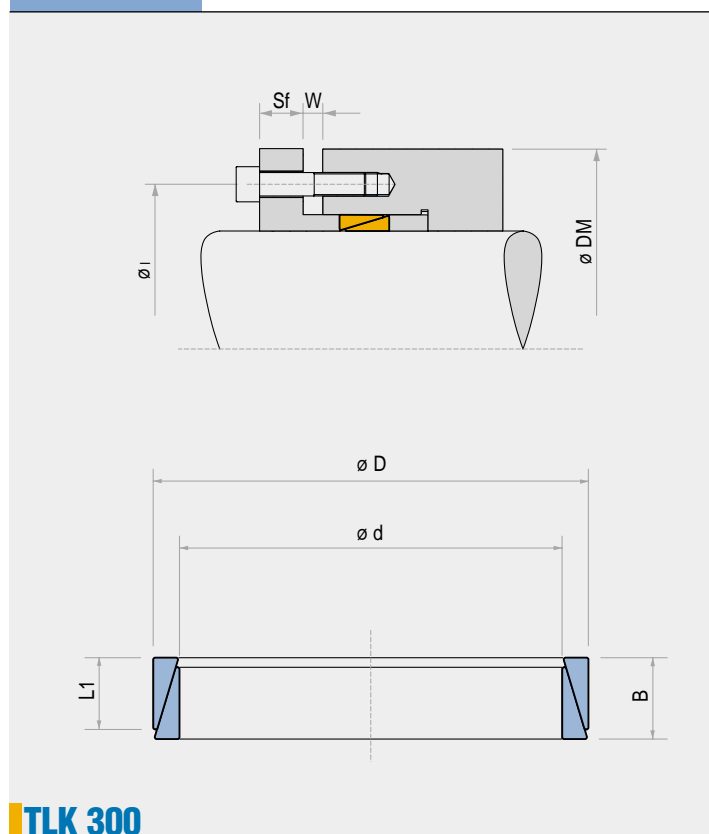

TLK 300

Screws center distance $l = D + 12 + dg$ (screws fixed on the hub)
Screws center distance $l = d - 12 - dg$ (screws fixed on the shaft)

Note: On request the type TLK 300 can be supplied also with split rings: therefore the transmissible torque M_t increases. Please contact our technical department.

Characteristics

- Medium low torque
- Restricted radial encumbrance
- Limited installation time
- Application economically advantageous

Installation

Carefully clean the hub and shaft contact surfaces and apply a light oil film. Slide the locking elements into the hub bore, insert the shaft and tighten gradually and regularly in crossed sequence all screws to reach the tightening torque M_s as indicated in the table. The values M_t and F_{ass} indicated in the table are valid only in case of oil installation. Do not use any oil with **molybdenum bisulphide** or high pressure additives and not grease. Above substances notably reduce the friction coefficient.

Dismantling

By loosening all tightening screws the locking elements are released and the clamping is free. However in case of difficulties slightly hammer the hub.

dg	DIN 912			C=0,140		
	Pv in N			Ms in Nm		
	8.8	10.9	12.9	8.8	10.9	12.9
M4	3900	5450	6550	2,9	4,1	4,9
M5	6350	8950	10700	6	8,5	10
M6	9000	12600	15100	10	14	17
[M7]	13200	18500	22200	16	23	28
M8	16500	23200	27900	25	35	41
[M9]	22000	30900	37100	36	51	61
M10	26200	36900	44300	49	69	83
M12	38300	54000	64500	86	120	145
M14	52500	74000	88500	135	190	230
M16	73000	102000	123000	210	295	355
M18	88000	124000	148000	290	405	485
M20	114000	160000	192000	410	580	690
M22	141000	199000	239000	550	780	930
M24	164000	230000	276000	710	1000	1200
M27	215000	302000	363000	1050	1500	1800
M30	262000	368000	442000	1450	2000	2400

$P_a = N^\circ \text{ of screws} \cdot P_v$

$P_t = \text{see page 19}$

$$M_t \text{ transmissible} = \frac{P_a - P_t}{0,54} \cdot 0,12 \cdot \frac{d}{2000}$$

Flange thickness $S_f = dg \cdot 1,3$ (screws quality 8.8)
Flange thickness $S_f = dg \cdot 1,8$ (screws quality 12.9)

Tolerances, surface finish

A good surface finish by machine tool is sufficient.
Maximum allowable surface finish:
 $R_t \text{ max } 6 \mu\text{m} (Ra \ 1 \mu\text{m} - Rz \ 5 \mu\text{m})$

Maximum permissible tolerances:
shaft h6 - hub H7 (up to 40mm d. diameter)
shaft h8 - hub H8 (over 42mm d. diameter)

Mt transmissible

- Nr. 1 TLK 300 $M_t = M_t \text{ cat.}$
- Nr. 2 TLK 300 $M_t = M_t \text{ cat.} \cdot 1,55$
- Nr. 3 TLK 300 $M_t = M_t \text{ cat.} \cdot 1,85$
- Nr. 4 TLK 300 $M_t = M_t \text{ cat.} \cdot 2,02$

DM hub calculation

The pressure P_n in the hub can be compared to the inside pressure on a thick hollow cylinder.

For DM calculation see page 38.

Locking elements not self-centering TLK 300

Dimensions			Pre-load force	Total force	Torque	Axial thrust	Distance W before tightening				Spacer diameter		Surface pressures on shaft		Weight
dxD mm	B mm	L1 mm	Pt N	Pa N	Mt Nm	F ass. KN	1 mm	2 mm	3 mm	4 mm	d1 mm	D1 mm	pw N/mm²	pn N/mm²	Kg
6 x 9	4,5	3,7	-	3800	2	0,84	2,5	2,5	3	4	6,1	8,9	115	75	0,002
7 x 10	4,5	3,7	-	3900	3	0,86	2,5	2,5	3	4	7,1	9,9	105	70	0,002
8 x 11	4,5	3,7	-	5300	5	1,17	2,5	2,5	3	4	8,1	10,9	120	90	0,002
9 x 12	4,5	3,7	7650	15600	8	1,76	2,5	2,5	3	4	9,1	11,9	140	105	0,00
10 x 13	4,5	3,7	7000	15600	10	1,91	2,5	2,5	3	4	10,1	12,9	135	105	0,002
12 x 15	4,5	3,7	7000	15600	11	1,91	2,5	2,5	3	4	12,1	14,9	115	90	0,002
13 x 16	4,5	3,7	6500	15600	13	2,02	2,5	2,5	3	4	13,1	15,9	110	90	0,00
14 x 18	6,3	5,3	11000	25400	22	3,18	3,5	3,5	4,5	5,5	14,1	17,9	115	90	0,005
15 x 19	6,3	5,3	10800	25400	24	3,24	3,5	3,5	4,5	5,5	15,1	18,9	110	85	0,005
16 x 20	6,3	5,3	10000	25400	27	3,42	3,5	3,5	4,5	5,5	16,1	19,9	105	85	0,006
17 x 21	6,3	5,3	9600	25400	30	3,51	3,5	3,5	4,5	5,5	17,1	20,9	105	85	0,006
18 x 22	6,3	5,3	9150	25400	32	3,61	3,5	3,5	4,5	5,5	18,1	21,9	100	80	0,007
19 x 24	6,3	5,3	12500	36000	49	5,22	3,5	3,5	4,5	5,5	19,2	23,8	140	110	0,007
20 x 25	6,3	5,3	12000	36000	53	5,33	3,5	3,5	4,5	5,5	20,2	24,8	135	105	0,009
22 x 26	6,3	5,3	9000	36000	66	6	3,5	3,5	4,5	5,5	22,2	25,8	135	115	0,007
24 x 28	6,3	5,3	8400	36000	73	6,13	3,5	3,5	4,5	5,5	24,2	27,8	130	110	0,008
25 x 30	6,3	5,3	10000	36000	72	5,77	3,5	3,5	4,5	5,5	25,2	29,8	115	95	0,009
28 x 32	6,3	5,3	7500	36000	88	6,33	3,5	3,5	4,5	5,5	28,2	31,8	115	100	0,01
30 x 35	6,3	5,3	8600	36000	91	6,08	3,5	3,5	4,5	5,5	30,2	34,8	100	85	0,011
32 x 36	6,3	5,3	7900	45000	131	8,24	3,5	3,5	4,5	5,5	32,2	35,8	130	115	0,011
35 x 40	7	6	10000	54000	171	9,77	3,5	3,5	4,5	5,5	35,2	39,8	125	110	0,016
36 x 42	7	6	11700	54000	169	9,39	3,5	3,5	4,5	5,5	36,2	41,8	115	100	0,019
38 x 44	7	6	11000	54000	181	9,55	3,5	3,5	4,5	5,5	38,2	43,8	110	95	0,021
40 x 45	8	6,6	13900	66000	231	11,57	3,5	4,5	5,5	6,5	40,2	44,8	115	105	0,021
42 x 48	8	6,6	15550	66000	235	11,22	3,5	4,5	5,5	6,5	42,2	47,8	110	95	0,026
45 x 52	10	8,6	28300	99000	353	15,71	3,5	4,5	5,5	6,5	45,2	51,8	105	95	0,045
48 x 55	10	8,6	24700	132000	572	23,84	3,5	4,5	5,5	6,5	48,2	54,8	155	135	0,043
50 x 57	10	8,6	23600	132000	602	24,08	3,5	4,5	5,5	6,5	50,2	56,8	150	130	0,045
55 x 62	10	8,6	21700	132000	670	24,35	3,5	4,5	5,5	6,5	55,2	61,8	140	125	0,049
56 x 64	12	10,4	29500	157200	790	28,2	3,5	4,5	5,5	7	56,2	63,8	130	115	0,07
60 x 68	12	10,4	27500	157200	860	28,6	3,5	4,5	5,5	7	60,2	67,8	125	110	0,07
63 x 71	12	10,4	26500	157200	910	28,8	3,5	4,5	5,5	7	63,2	70,8	120	105	0,08
65 x 73	12	10,4	25500	157200	950	29,2	3,5	4,5	5,5	7	65,2	72,8	115	100	0,09
70 x 79	14	12,2	31000	209600	1380	39,4	3,5	5	6,5	7,5	70,3	78,7	125	110	0,115
71 x 80	14	12,2	31000	209600	1400	39,4	3,5	5	6,5	7,5	71,3	79,7	120	110	0,11
75 x 84	14	12,2	34700	209600	1450	38,6	3,5	5	6,5	7,5	75,3	83,7	115	100	0,12
80 x 91	17	15	48000	290000	2200	55	4	6	6,5	8	80,3	90,7	125	105	0,21
85 x 96	17	15	45500	305000	2400	56,4	4	6	6,5	8	85,3	95,7	120	105	0,21
90 x 101	17	15	43600	320000	2730	60,5	4	6	6,5	8	90,3	100,7	120	105	0,22
95 x 106	17	15	41300	330000	3050	64,2	4	6	6,5	8	95,3	105,7	120	110	0,23
100 x 114	21	18,7	61000	445000	4200	84	5	6	7	9	100,3	113,7	120	105	0,39
110 x 124	21	18,7	66000	485000	5150	93,6	5	6	7	9	110,3	123,7	120	105	0,42
120 x 134	21	18,7	60300	510000	6050	100,8	5	6	7	9	120,2	133,7	120	105	0,46
130 x 148	28	25,3	96300	765000	9600	147,6	5	7	9	11	130,4	147,6	120	105	0,86
140 x 158	28	25,3	89000	800500	11000	158,5	6	7	9	11	140,4	157,6	120	105	0,96
150 x 168	28	25,3	85000	860000	12900	172	6	7	8	11	150,4	167,6	120	105	1
160 x 178	28	25,3	78600	900000	14600	182,5	6	7	9	11	160,4	177,6	120	110	1
170 x 191	33	30	117400	1160000	19500	229	7	9	10	12	170,5	190,5	120	105	1,54
180 x 201	33	30	111300	1200000	21300	236	7	9	10	12	180,5	200,5	120	105	1,5
190 x 211	33	30	105000	1260000	24200	255	7	9	10	12	190,5	210,5	120	110	1,8
200 x 224	38	34,8	134200	1550000	31000	310	7	8	11	13	200,6	223,4	120	105	2,4
210 x 234	38	34,8	127200	1610000	35000	333	7	9	11	13	210,6	233,4	120	110	2,5
220 x 244	38	34,8	122100	1690000	38000	345	7	9	11	13	220,6	243,4	120	110	2,6
230 x 257	43	39,5	164500	2000000	47000	408	7	10	12	14	230,6	256,4	120	105	3,4
240 x 267	43	39,5	157400	2250000	51000	425	7	10	12	14	240,6	266,4	120	110	3,8
250 x 280	48	44	190000	2060000	52000	415	7	10	13	16	250,8	279,2	100	89	4,8
260 x 290	48	44	182000	2132000	56500	435	7	10	13	16	260,8	289,2	100	89	4,9
270 x 300	48	44	177000	2207000	61000	450	7	10	13	16	270,8	299,2	100	89	5
280 x 313	53	49	206000	2536000	72500	520	7	11	14	17	280,8	312,2	100	89	6,4
290 x 323	53	49	222000	2632000	77500	535	7	11	14	17	290,8	322,2	100	89	6,5
300 x 333	53	49	214000	2704000	83000	555	7	11	14	17	300,8	332,2	100	89	6,8
320 x 360	65	59	292000	3492000	114000	710	10	15	20	25	321	359	100	89	11
340 x 380	65	59	272000	3672000	128500	755	10	15	20	25	341	379	100	89	11,5
360 x 400	65	59	258000	3858000	144000	800	10	15	20						

Locking assembly self-centering TLK 350

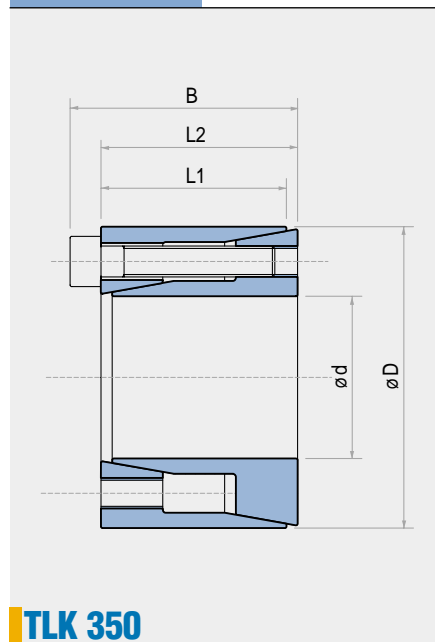

dxD mm	L1 mm	L2 mm	B mm	Torque Mt Nm	Axial Thrust F ass. KN	Surface pressures on		Tightening screws Tightening torque		Weight Kg
						Shaft pw N/mm ²	hub pn N/mm ²	DIN 912 12.9 N° x type Ms Nm		
6 x 16	10,5	11	13,5	9	3	184	69	3 x M2,5	1,2	0,012
6,35 x 16	10,5	11	13,5	10	3	173	69	3 x M2,5	1,2	0,012
7 x 17	10,5	11	13,5	11	3	157	65	3 x M2,5	1,2	0,013
8 x 18	10,5	11	13,5	12	3	138	61	3 x M2,5	1,2	0,015
9 x 20	12,5	13	15,5	18	4	138	62	4 x M2,5	1,2	0,02
9,53 x 20	12,5	13	15,5	19	4	130	62	4 x M2,5	1,2	0,02
10 x 20	12,5	13	15,5	20	4	124	62	4 x M2,5	1,2	0,019
11 x 22	12,5	13	15,5	22	4	113	56	4 x M2,5	1,2	0,024
12 x 22	12,5	13	15,5	24	4	104	56	4 x M2,5	1,2	0,022
14 x 26	16,5	17	20	42	6	99	53	4 x M3	2,1	0,039
15 x 28	16,5	17	20	44	6	93	50	4 x M3	2,1	0,044
16 x 32	16,5	17	21	83	10,4	152	76	4 x M4	4,9	0,067
17 x 35	20,5	21	25	88	10,4	116	56	4 x M4	4,9	0,09
18 x 35	20,5	21	25	93	10,4	109	56	4 x M4	4,9	0,087
19 x 35	20,5	21	25	99	10,4	104	56	4 x M4	4,9	0,083
20 x 38	20,5	21	26	170	17	161	85	4 x M5	10	0,1
22 x 40	20,5	21	26	187	17	146	80	4 x M5	10	0,11
24 x 47	25	26	32	287	24	153	78	4 x M6	17	0,2
25 x 47	25	26	32	299	24	147	78	4 x M6	17	0,19
25,4 x 47	25	26	32	304	24	144	78	4 x M6	17	0,18
28 x 50	25	26	32	503	36	196	110	6 x M6	17	0,22
30 x 55	25	26	32	539	36	183	100	6 x M6	17	0,27
32 x 55	25	26	32	575	36	172	100	6 x M6	17	0,25
35 x 60	30	31	37	838	48	176	102	8 x M6	17	0,36
38 x 65	30	31	37	910	48	162	95	8 x M6	17	0,43
40 x 65	30	31	37	958	48	154	95	8 x M6	17	0,4
42 x 75	35	36	44	1394	66,3	175	98	6 x M8	41	0,67
45 x 75	35	36	44	1493	66,3	163	98	6 x M8	41	0,63
48 x 80	35	36	44	2124	88,5	204	122	8 x M8	41	0,74
50 x 80	35	36	44	2212	88,5	196	122	8 x M8	41	0,7

TLK 350

Characteristics

- Medium-high torque
- Easy mounting
- Limited installation time
- Few clamping screws

Installation

Carefully clean the hub and shaft contact surfaces and apply a light oil film. Slide the locking assembly into the hub bore, insert the shaft and tighten gradually and regularly in crossed sequence all screws to reach the tightening torque **Ms** as indicated in the table. The values **Mt** and **F ass** indicated in the table are valid only in case of oil installation. Do not use any oil with **molibdenum bisulphide** or high pressure additives and not grease. Above substances notably reduce the friction coefficient.

Dismantling

Loosen the clamping screws. Insert the screws into the dismantling threading and tighten gradually and regularly in crossed sequence until the back cone is released. If the element is to be reused, relubricate both screws and threads.

Tolerances, surface finish

A good surface finish by the machine tool is sufficient. Maximum allowable surface finish:
Rt max 16 µm (Ra 3 µm - Rz 13 µm)

Maximum permissible tolerances:
h8 for shaft
H8 for hub

Axial movement

TLK 350: during screws tightening the hub has a slight axial movement with respect to the shaft.

DM hub calculation

The pressure **Pn** in the hub can be compared to the inside pressure on a thick hollow cylinder.

For DM calculation see page 38.

Locking assemblies self-centering patented TLK 400 • TLK 401

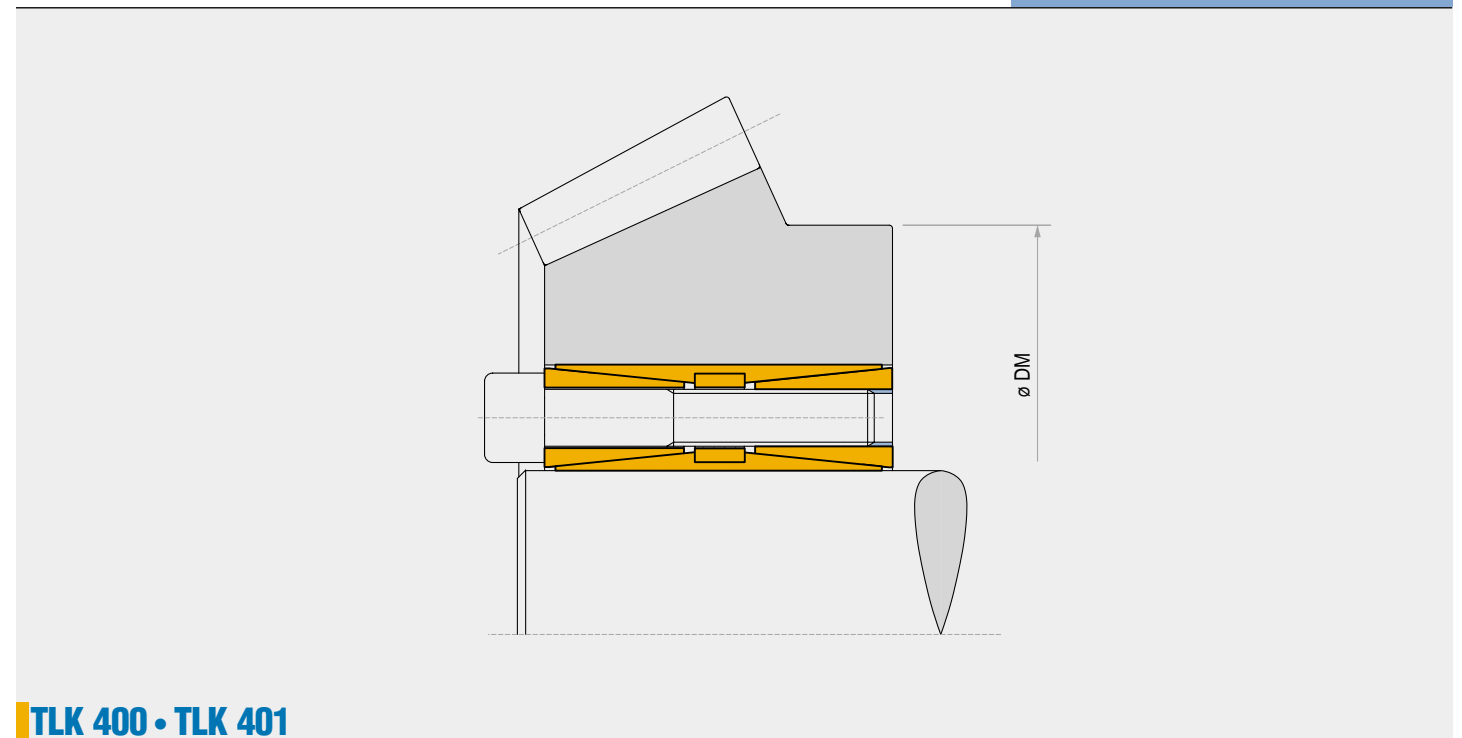

TLK 400 • TLK 401

Characteristics

- Very high torques
- Capacity to withstand bending moments
- Even pressures distribution
- No shaft-hub axial movement

Installation

Carefully clean the hub and shaft contact surfaces and apply a light oil film. Slide the locking assembly into the hub bore and insert the shaft. Tighten gradually and regularly in crossed sequence all screws up to 50% of the **Ms** value indicated in the table. Repeat the same operation by tightening all screws at the **Ms** torque indicated in the table. Starting from the last tightened screw, check, in continuous sequence, that all the screws are tightened at the tightening torque **Ms** indicated. Repeat this procedure maximum twice. After this control any further operation is needed. Do not use any oil with **molybdenum bisulphide** or high pressure additives and not grease. Above substances notably reduce the friction coefficient.

Dismantling

Loosen the clamping screws. Insert the screws into the dismantling threads of the front cone and tighten them gradually in crossed sequence up to 50% of the **Ms** value indicated in the table. Repeat the same operation by tightening the screws at the tightening torque **Ms** indicated in the table. When the front cone is loose, to release the rear cone, insert the screws in the middle ring, and repeat the same operation of the upper ring.

Tolerances, surface finish

A good surface finish by machine tool is sufficient. Maximum allowable surface finish:
Rt max 16 µm (Ra 3 µm - Rz 13 µm)

Maximum permissible tolerances:
h8 for shaft
H8 for hub

Axial movement

During screws tightening the hub has no axial movement with respect to the shaft.

DM hub calculation

For DM hub calculation see page 38.

ATTENTION: In case of reuse of the TLK400 or TLK401 check that the position of the dismantling threads of the front cone and middle ring are like in new pieces.

Locking assembly self-centering patented TLK 400

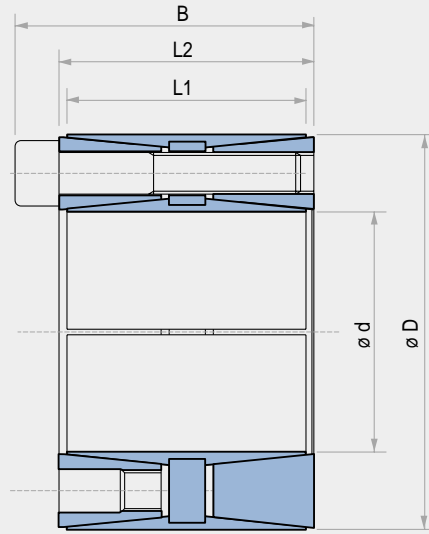

TLK 400

dxD mm	L1 mm	L2 mm	B mm	Tightening screws		Torque Mt Nm	Axial Thrust F ass. KN	Surface pressures on		Weight Kg
				DIN 912 N° x type	Tightening torque Ms Nm			Shaft pw N/mm ²	Hub pn N/mm ²	
45 x 75	56	64	72	8 x M8	41	3460	155	165	100	1,3
48 x 80	56	64	72	8 x M8	41	3680	155	150	95	1,5
50 x 80	56	64	72	8 x M8	41	3820	155	147	95	1,4
55 x 85	56	64	72	8 x M8	41	4260	155	135	85	1,5
60 x 90	56	64	72	10 x M8	41	5820	190	155	100	1,5
65 x 95	56	64	72	10 x M8	41	6270	190	140	95	1,6
70 x 110	70	78	88	10 x M10	83	10730	305	170	105	3
75 x 115	70	78	88	10 x M10	83	11540	305	155	100	3,1
80 x 120	70	78	88	12 x M10	83	14700	369	175	115	3,5
85 x 125	70	78	88	12 x M10	83	15700	369	165	110	3,5
90 x 130	70	78	88	12 x M10	83	16610	370	157	106	3,8
95 x 135	70	78	88	12 x M10	83	17530	370	150	102	4
100 x 145	90	100	112	12 x M12	145	26900	538	160	110	6
110 x 155	90	100	112	12 x M12	145	29530	538	143	102	6,2
120 x 165	90	100	112	14 x M12	145	37610	628	154	112	6,8
130 x 180	104	116	130	12 x M14	230	48000	738	143	106	9,8
140 x 190	104	116	130	14 x M14	230	60290	861	160	117	10,2
150 x 200	104	116	130	16 x M14	230	73800	985	165	125	10,9
160 x 210	104	116	130	16 x M14	230	78770	983	155	118	11,5
170 x 225	134	146	162	14 x M16	355	101730	1197	140	108	17,2
180 x 235	134	146	162	16 x M16	355	123200	1369	150	115	18
190 x 250	134	146	162	16 x M16	355	129880	1368	141	110	21,5
200 x 260	134	146	162	16 x M16	355	136840	1368	137	104	22
220 x 285	134	146	162	20 x M16	355	188000	1710	155	120	25
240 x 305	134	146	162	22 x M16	355	225000	1880	155	120	27
260 x 325	134	146	162	22 x M16	355	244000	1880	155	115	30
280 x 355	165	177	197	20 x M20	690	373000	2670	145	120	46
300 x 375	165	177	197	22 x M20	690	440000	2930	155	125	50
320 x 405	165	177	197	22 x M20	690	470000	2930	145	115	60
340 x 425	165	177	197	24 x M20	690	544000	3200	150	120	65
360 x 455	190	202	224	22 x M22	930	658000	3650	140	110	89
380 x 475	190	202	224	26 x M22	930	821000	4320	160	130	93
400 x 495	190	202	224	26 x M22	930	864000	4320	150	120	98

For larger diameter or inch series please contact us.

NOTE: it is possible to reduce the screws tightening torque down to 60% of the values indicated in the above table; as a result Mt, Fass, Pw, Pn are reduced proportionally.

Locking assemblies self-centering patented TLK 401 • TLK 401.0

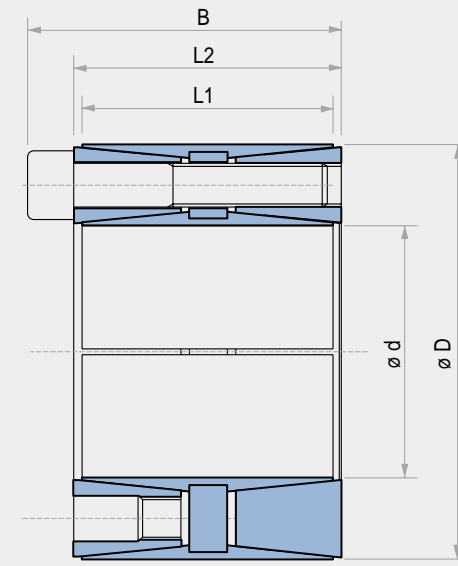

TLK 401 • TLK 401.0

dxD mm	L1 mm	L2 mm	B mm	Tightening screws DIN 912 N° x type	TLK 401		TLK 401.0		Surface pressures on		Tightening torque Ms Nm	Torque Mt Nm	Axial Force F ass. KN	Surface pressures on		Weight Kg
					Tightening torque Ms Nm	Torque Mt Nm	Shaft pw N/mm ²	Hub pn N/mm ²	Shaft pw N/mm ²	Hub pn N/mm ²						
70 x 110	50	58	68	8 x M10	49	5100	145	112	71	83	8620	245	190	120	2,3	
75 x 115	50	58	68	8 x M10	49	5420	145	103	68	83	9160	245	174	115	2,4	
80 x 120	50	58	68	8 x M10	49	5820	145	97	65	83	9840	245	164	110	2,5	
85 x 125	50	58	68	10 x M10	49	7700	182	114	77	83	13000	307	193	130	2,6	
90 x 130	50	58	68	10 x M10	49	8100	182	107	74	83	13700	307	181	125	2,7	
95 x 135	50	58	68	10 x M10	49	8600	182	102	72	83	14540	307	173	122	2,8	
100 x 145	60	70	80	10 x M10	49	9100	182	80	55	83	15380	307	135	93	4	
110 x 155	60	70	80	10 x M10	49	10000	182	75	52	83	16900	307	127	88	4,5	
120 x 165	60	70	80	12 x M10	49	13100	218	80	59	83	22150	365	135	100	4,8	
130 x 180	68	80	92	12 x M12	86	20700	319	95	69	145	34860	537	160	116	6,3	
140 x 190	68	80	92	12 x M12	86	22300	319	89	66	145	37550	537	150	111	6,6	
150 x 200	68	80	92	12 x M12	86	23900	319	83	62	145	40250	537	140	105	7	
160 x 210	68	80	92	14 x M12	86	29800	372	90	69	145	50180	626	152	116	7,4	
170 x 225	75	87	99	16 x M12	86	36200	426	89	67	145	60960	717	150	113	10	
180 x 235	75	87	99	16 x M12	86	38300	426	84	64	145	64500	717	142	108	11,3	
190 x 250	88	100	112	18 x M12	86	45500	479	76	58	145	76620	806	128	98	14	
200 x 260	88	100	112	18 x M12	86	47900	479	72	56	145	80660	806	122	95	15,2	
220 x 285	98	110	124	14 x M14	135	56200	511	63	49	230	94730	861	107	83	19,5	
240 x 305	98	110	124	18 x M14	135	78800	657	74	58	230	132830	1100	125	98	21,5	
260 x 325	98	110	124	20 x M14	135	94900	730	76	61	230	159970	1230	128	103	23	
280 x 355	120	132	148	20 x M16	210	142000	1015	80	63	355	239260	1710	135	106	29	
300 x 375	120	132	148	24 x M16	210	182000	1218	89	72	355	306650	2050	150	121	30,5	
320 x 405	135	147	163	24 x M16	210	194000	1218	75	60	355	326870	2050	127	101	47	
340 x 425	135	147	163	24 x M16	210	207000	1218	71	57	355	348780	2050	120	96	50	

For larger diameter or inch series please contact us.

Locking assemblies self-centering TLK 450 • TLK 451

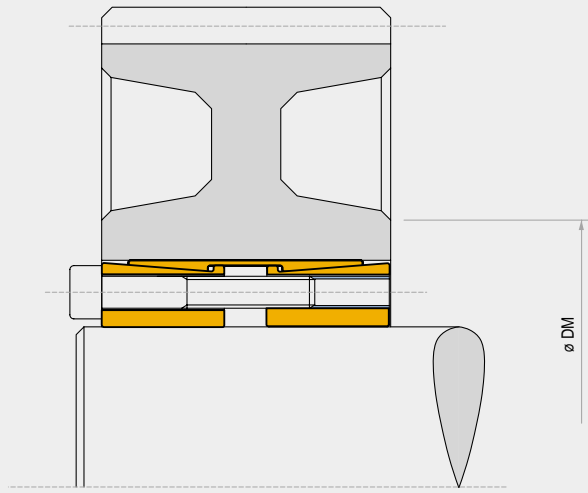

TLK 450

Characteristics

- Very high torques
- Capacity to withstand bending moments
- Standard sizes

Installation

Carefully clean the hub and shaft contact surfaces and apply a light oil film. Slide the locking assembly into the hub bore and insert the shaft. Tighten gradually and regularly in crossed sequence all screws up to 50% of the **Ms** value indicated in the table. Repeat the same operation by tightening all screws at the **Ms** torque indicated in the table.

Starting from the last tightened screw, check, in continuous sequence, that all the screws are tightened at the tightening torque **Ms** indicated. Repeat this procedure maximum twice. After this control any further operation is needed.

Do not use any oil with **molybdenum bisulphide** or high pressure additives and not grease. Above substances notably reduce the friction coefficient.

Dismantling

Loosen the clamping screws. Insert the screws into the dismantling threads of the front cone and tighten them gradually in crossed sequence up to 50% of the **Ms** value indicated in the table. Repeat the same operation by tightening the screws at the tightening torque **Ms** indicated in the table.

When the front cone is loose, to release the rear cone:

TLK450: keep tightening the screws and repeat the sequence above.

TLK451: insert the screws in the middle flange and repeat the same operation of the upper ring.

Tolerances, surface finish

A good surface finish by machine tool is sufficient. Maximum allowable surface finish:

$$Rt \text{ max } 16 \mu\text{m} \text{ (Ra } 3 \mu\text{m} - Rz 13 \mu\text{m)}$$

Maximum permissible tolerances:

- h8 for shaft**
- H8 for hub**

DM hub calculation

For DM hub calculation see page 38.

ATTENTION: In case of reuse of the TLK451 check that the position of the dismantling threads of the front cone and middle flange are like in new pieces.

Locking assembly self-centering TLK 450

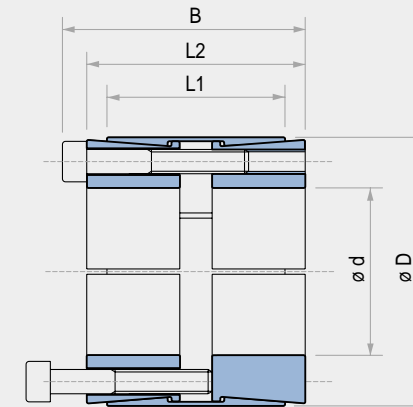

TLK 450

dxD mm	L1 mm	L2 mm	B mm	Tightening screws		Torque Mt Nm	Axial Thrust F ass. KN	Surface pressures on		Weight Kg
				DIN 912 12.9 N° x type	Tightening torque Ms Nm			Shaft pw N/mm²	Hub pn N/mm²	
25 x 50	39	45	51	8 x M6	17	950	76	245	122	0,5
28 x 55	39	45	51	8 x M6	17	1070	76	219	111	0,6
30 x 55	39	45	51	8 x M6	17	1150	76	204	111	0,6
35 x 60	39	45	51	8 x M6	17	1340	76	175	102	0,7
38 x 65	39	45	51	8 x M6	17	1450	76	161	94	0,7
40 x 65	39	45	51	8 x M6	17	1530	76	153	94	0,7
42 x 75	56	64	72	8 x M8	41	2970	141	188	105	1
45 x 75	56	64	72	8 x M8	41	3150	141	175	105	0,9
48 x 80	56	64	72	8 x M8	41	4000	166	164	98	1,4
50 x 80	56	64	72	8 x M8	41	4150	166	158	98	1,3
55 x 85	56	64	72	8 x M8	41	4550	166	143	93	1,5
60 x 90	56	64	72	10 x M8	41	6200	207	164	109	1,6
65 x 95	56	64	72	10 x M8	41	6750	207	152	104	1,8
70 x 110	70	78	88	10 x M10	83	11550	330	179	114	3
75 x 115	70	78	88	10 x M10	83	12350	330	167	109	3,3
80 x 120	70	78	88	12 x M10	83	15800	396	188	125	3,5
85 x 125	70	78	88	12 x M10	83	16800	396	177	120	3,7
90 x 130	70	78	88	12 x M10	83	17800	396	167	115	3,8
95 x 135	70	78	88	12 x M10	83	18800	396	158	111	5
100 x 145	90	100	112	12 x M12	145	28800	576	170	117	6
110 x 155	90	100	112	12 x M12	145	31700	576	155	110	6,2
120 x 165	90	100	112	14 x M12	145	40300	673	165	120	7,2
130 x 180	104	116	130	12 x M14	230	51400	791	155	112	10
140 x 190	104	116	130	14 x M14	230	64600	923	168	124	10,2
150 x 200	104	116	130	16 x M14	230	79100	1055	179	135	10,8
160 x 210	104	116	130	16 x M14	230	84400	1055	168	128	11,5
170 x 225	134	146	162	14 x M16	355	109000	1283	149	113	17
180 x 235	134	146	162	16 x M16	355	132000	1466	161	124	18,5
190 x 250	134	146	162	16 x M16	355	139000	1466	153	116	21,5
200 x 260	134	146	162	16 x M16	355	146500	1466	145	112	22
220 x 285	134	146	162	20 x M16	355	201500	1833	165	127	25
240 x 305	134	146	162	22 x M16	355	242000	2017	166	131	27
260 x 325	134	146	162	22 x M16	355	262000	2017	154	123	30
280 x 355	165	177	197	20 x M20	690	400000	2862	164	130	46
300 x 375	165	177	197	22 x M20	690	472000	3148	169	135	50
320 x 405	165	177	197	22 x M20	690	503500	3148	158	125	60
340 x 425	165	177	197	24 x M20	690	583500	3434	162	130	65
360 x 455	190	202	224	22 x M22	930	705000	3918	152	120	89
380 x 475	190	202	224	26 x M22	930	880000	4631	170	136	93
400 x 495	190	202	224	26 x M22	930	926000	4631	162	131	98

For larger diameter or inch series please contact us.

NOTE: it is possible to reduce the screws tightening torque down to 60% of the values indicated in the above table; as a result Mt, Fass, Pw, Pn are reduced proportionally.

Locking assemblies self-centering TLK 451 • TLK 451.0

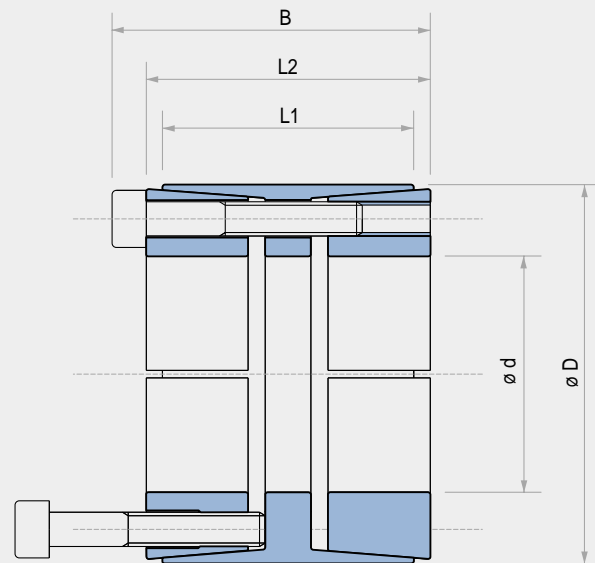

TLK 451 • TLK 451.0

TLK 451										TLK 451.0						
dxD mm	L1 mm	L2 mm	B mm	Tightening screws DIN 912 12.9 N° x type	Tightening torque Ms Nm	Torque Mt Nm	Axial Force F ass. KN	Surface pressures on		Tightening torque Ms Nm	Torque Mt Nm	Axial Force F ass. KN	Surface pressures on		Weight TLK 451 TLK 451.0 Kg	
								Shaft pw N/mm ²	Hub pn N/mm ²				Shaft pw N/mm ²	Hub pn N/mm ²		
70 x 110	50	60	70	8 x M10	49	4180	120	113	64	83	7090	203	192	109	2,3	
80 x 120	50	60	70	10 x M10	49	5980	150	124	73	83	10130	253	210	124	2,5	
90 x 130	50	60	70	11 x M10	49	7400	165	121	75	83	12540	279	205	126	2,7	
100 x 145	60	70	82	10 x M12	86	10930	219	121	74	145	18440	369	204	125	4,1	
110 x 155	60	70	82	10 x M12	86	12000	219	110	69	145	20200	369	185	117	4,4	
120 x 165	60	70	82	11 x M12	86	14400	241	111	72	145	24300	406	187	121	4,8	
130 x 180	65	79	91	14 x M12	86	19900	306	118	77	145	33500	516	199	129	6,3	
140 x 190	65	79	91	15 x M12	86	22900	328	117	78	145	38700	553	198	131	6,6	
150 x 200	65	79	91	15 x M12	86	24600	328	110	74	145	41400	553	185	124	7,8	
160 x 210	65	79	91	16 x M12	86	28000	350	110	75	145	47200	590	185	126	7,4	
170 x 225	78	92	106	15 x M14	135	37800	446	109	74	230	64500	759	185	126	10,7	
180 x 235	78	92	106	15 x M14	135	40100	446	103	71	230	68300	759	175	121	11,3	
190 x 250	88	102	116	16 x M14	135	45100	475	90	62	230	76900	810	153	106	14,6	
200 x 260	88	102	116	18 x M14	135	53400	535	96	67	230	91100	911	163	115	15,3	
220 x 285	96	108	124	15 x M16	210	68600	624	94	66	355	116000	1055	159	112	20,2	
240 x 305	96	108	124	20 x M16	210	99800	832	115	82	355	168800	1407	194	139	21,8	
260 x 325	96	108	124	20 x M16	210	108000	832	106	77	355	182000	1407	179	130	23,4	
280 x 355	96	110	130	15 x M20	410	137000	979	122	85	690	230000	1647	205	143	30	
300 x 375	96	110	130	16 x M20	410	156000	1044	121	86	690	263000	1757	204	145	31,2	
320 x 405	124	136	156	20 x M20	410	208000	1305	104	75	690	351000	2196	175	126	48	
340 x 425	124	136	156	20 x M20	410	221000	1305	98	71	690	373000	2196	165	120	51	
360 x 455	140	155	177	20 x M22	550	291000	1617	101	73	930	492000	2734	171	124	69	
380 x 475	140	155	177	20 x M22	550	307000	1617	96	70	930	519000	2734	162	118	73	
400 x 495	140	155	177	22 x M22	550	355000	1778	100	74	930	601000	3007	169	125	76	
420 x 515	140	155	177	24 x M22	550	407000	1940	104	77	930	688000	3280	176	131	80	
440 x 535	140	155	177	24 x M22	550	426000	1940	99	75	930	721000	3280	168	126	81	
460 x 555	140	155	177	24 x M22	550	446000	1940	95	72	930	754000	3280	160	122	85	
480 x 575	140	155	177	25 x M22	550	485000	2021	95	72	930	820000	3417	160	122	88	
500 x 595	140	155	177	25 x M22	550	505000	2021	91	70	930	854000	3417	154	118	91	
520 x 615	140	155	177	28 x M22	550	588000	2263	98	76	930	995000	3827	165	128	95	
540 x 635	140	155	177	28 x M22	550	611000	2263	94	73	930	1033000	3827	159	124	98	
560 x 655	140	155	177	30 x M22	550	679000	2425	97	76	930	1148000	4101	165	129	101	
580 x 675	140	155	177	30 x M22	550	703000	2425	94	74	930	1189000	4101	159	125	104	
600 x 695	140	155	177	30 x M22	550	727000	2425	91	72	930	1230000	4101	154	121	108	

For larger diameter or inch series please contact us.

Rigid coupling TLK 500

dxD mm	L mm	B mm	Torque		Axial Thrust	Tightening screws DIN 912 12.9	Tightening torque	Weight
			Mt Nm	F ass. KN	N° x type	Ms Nm	Kg	
17 x 50	50	56	200	24	24	4 x M6	17	0,5
18 x 50	50	56	220	24	24	4 x M6	17	0,5
19 x 50	50	56	230	24	24	4 x M6	17	0,5
20 x 50	50	56	240	24	24	4 x M6	17	0,5
22 x 55	60	66	260	24	24	4 x M6	17	0,6
24 x 55	60	66	290	24	24	4 x M6	17	0,6
25 x 55	60	66	450	36	36	6 x M6	17	0,6
28 x 60	60	66	510	36	36	6 x M6	17	0,7
30 x 60	60	66	550	36	36	6 x M6	17	0,7
32 x 75	60	68	720	45	45	4 x M8	41	1,3
35 x 75	75	83	790	45	45	4 x M8	41	1,3
38 x 75	75	83	850	45	45	4 x M8	41	1,3
40 x 75	75	83	900	45	45	4 x M8	41	1,3
42 x 90	75	83	1400	67	67	6 x M8	41	2,8
45 x 90	85	93	1520	67	67	6 x M8	41	2,5
48 x 90	85	93	1620	67	67	6 x M8	41	2,4
50 x 90	85	93	1690	67	67	6 x M8	41	2,3
55 x 105	85	93	2470	90	90	8 x M8	41	3,3
60 x 105	85	93	2710	90	90	8 x M8	41	3,2
65 x 105	85	93	2930	90	90	8 x M8	41	3
70 x 125	100	110	3770	107	107	6 x M10	83	5,4
75 x 125	100	110	4030	107	107	6 x M10	83	5
80 x 125	100	110	4300	107	107	6 x M10	83	4,7

For larger diameter please contact us.

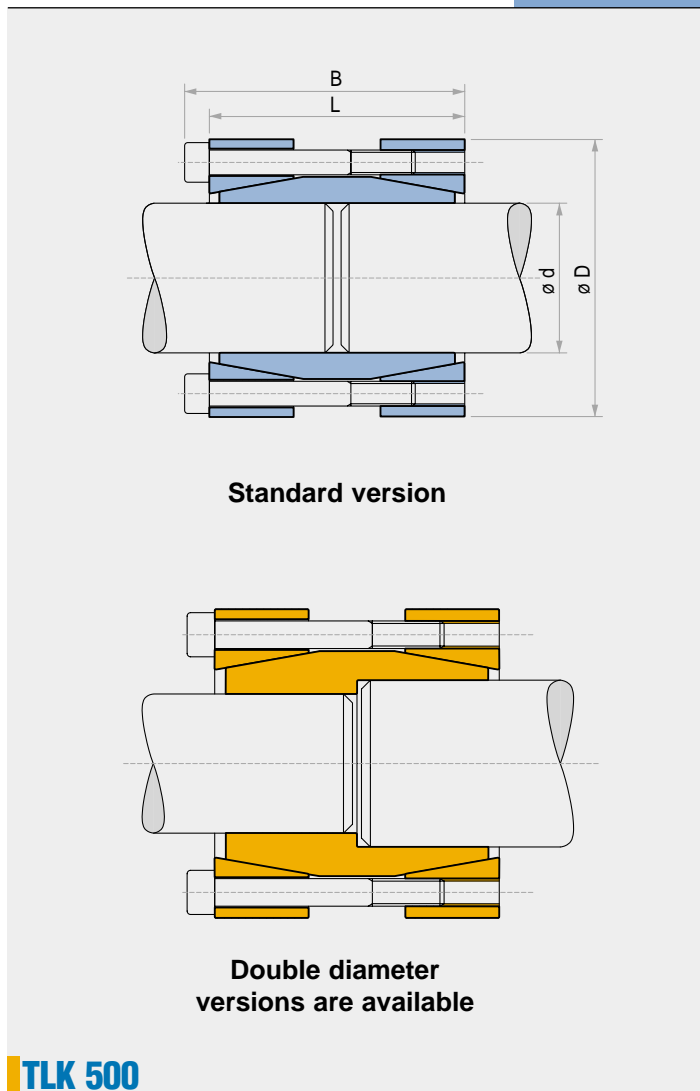

TLK 500

Characteristics

- Medium high torque
- Restricted number of tightening screws
- Easy installation
- Application economically advantageous

Installation

Carefully clean the shafts contact surfaces. Fit the rigid coupling at the end of the connecting shafts. Tighten gradually and regularly in crossed sequence all screws to reach the tightening torque **Ms** indicated on the table.

Dismantling

By loosening all tightening screws the clamping cones are normally released. However in case of difficulties slightly hammer the released screws in a way to push back the rear pressure cone.

Tolerances, surface finish

A good surface finish by machine tool is sufficient. Maximum allowable surface finish:
Rt max 16 µm (Ra 3 µm - Rz 13 µm)

Maximum permissible tolerances:
h8 for shaft

Shrink discs TLK 603 • TLK 602 • TLK 601

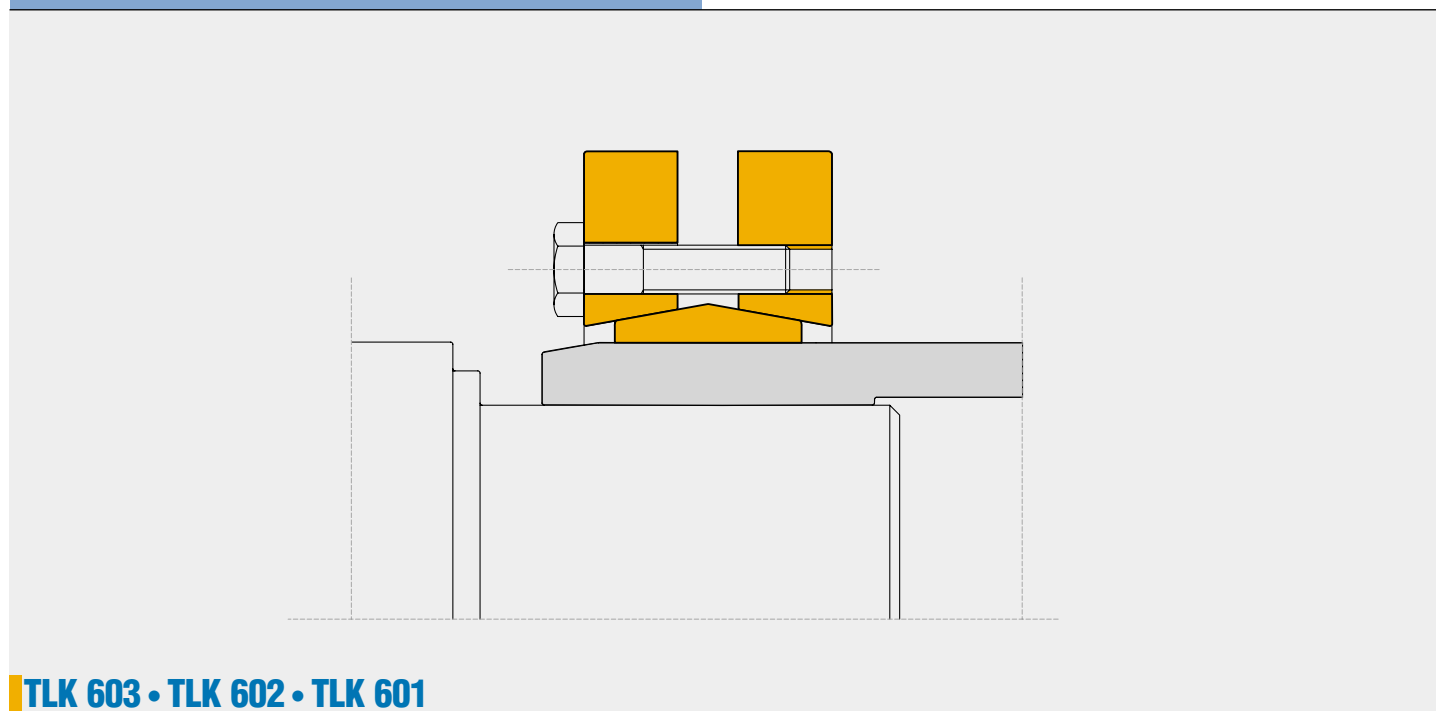

TLK 603 • TLK 602 • TLK 601

Characteristics

- Medium-high torque
- No shaft-hub axial movement
- Limited installation time
- Quick dismantling

Installation

Carefully clean the hub and shaft contact surfaces. Slide the shrink disc outside the hollow shaft. Tighten gradually and regularly in continuous sequence all screws to reach the tightening torque **Ms** indicated in the table. To reach the required tightening torque **Ms** it is necessary to repeat the procedure more than once. Do not use **molybdenum bisulphide** in the hub and shaft contact surfaces.

Dismantling

Loosen the clamping screws in a continuous and gradual sequence. Do not remove screws from threads. Normally with this operation the shrink disc is released. In case of reuse, apply a solid lubricant (that can guarantee a friction coefficient equal to 0,04) in the screws and in the tapered surfaces.

Tolerances, surface finish

A good surface finish by machine tool is sufficient. Maximum allowable surface finish:
Rt max 16 µm (Ra 3 µm - Rz 13 µm)

Maximum permissible tolerances:
d = h8 for shaft

dw diameter tolerances

From 18 mm to 30 mm dw	H6/j6
From 30 mm to 50 mm dw	H6/h6
From 50 mm to 80 mm dw	H6/g6
From 80 mm to 500 mm dw	H7/g6

Axial movement

During screws tightening the hub has no axial movement with respect to the shaft.

Shrink discs Special applications

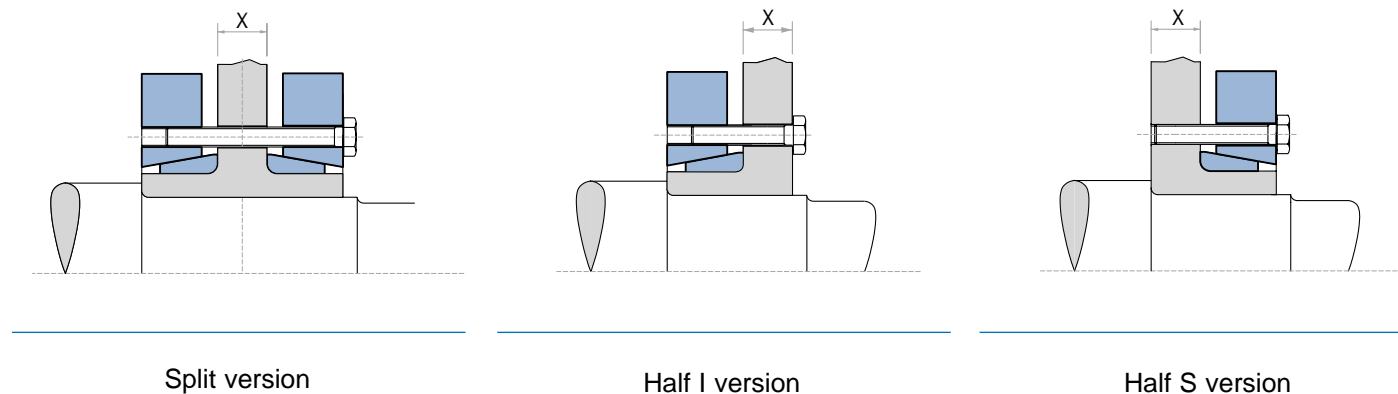

When ordering please specify X dimension

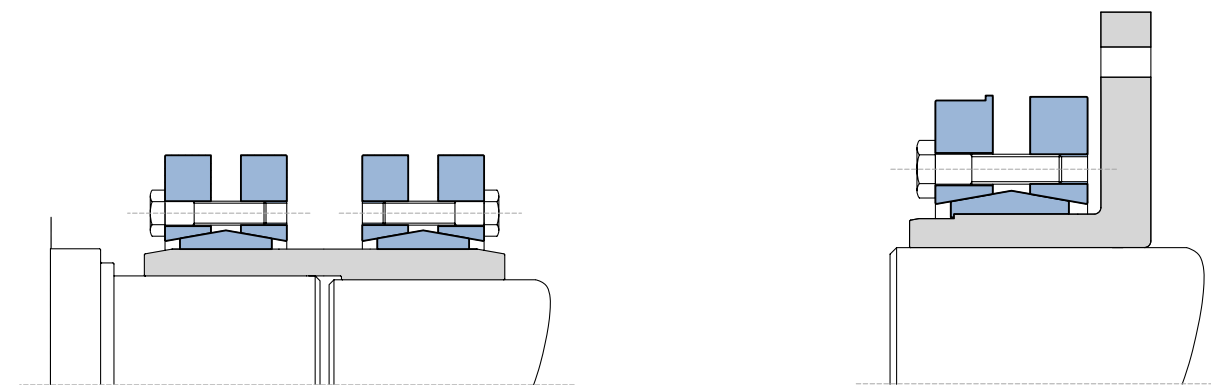

Use of model TLK 603 as coupling between different size shafts

Special version equipped with housing for brake

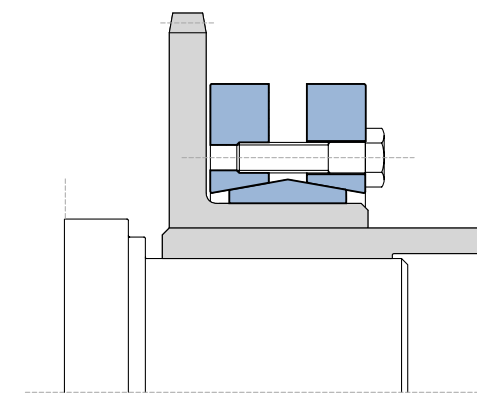

Contemporaneous locking of a sprocket and a hollow shaft.

Shrink disc standard version
TLK 603

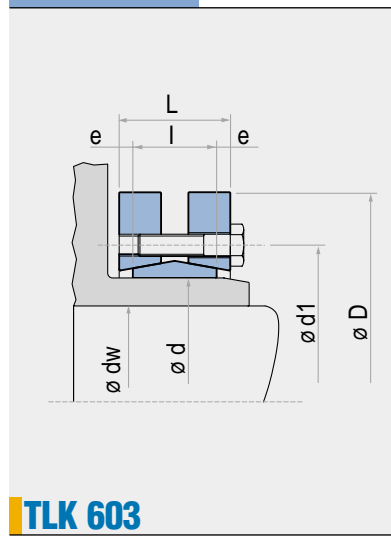

Type	Shaft diameter		Torque Mt Nm	Axial Thrust F ass. KN	Dimensions					Tightening screws DIN 931-10.9 N° x type	Tightening torque Ms Nm	Weight kg
	d mm	dw mm			D mm	I mm	L mm	d1 mm	e mm			
14	11	30	6									
	12	50	9	38	7	11,0	23	2,00	4 x M5*	4	0,1	
16	13	70	10									
	14	90	13	41	11	15,0	26	2,00	5 x M5*	4	0,1	
24	19	170	25									
	20	210	27	50	14	19,5	36	2,75	6 x M5*	4	0,2	
	21	250	29									
30	24	300	29									
	25	340	31	60	16	21,5	44	2,75	7 x M5*	4	0,3	
	26	380	33									
36	28	440	50									
	30	570	58	72	18	23,5	52	2,75	5 x M6	12	0,4	
	31	630	58									
44	32	620	64									
	35	780	74	80	20	25,5	61	2,75	7 x M6	12	0,6	
	36	860	77									
50	38	940	79									
	40	1160	86	90	22	27,5	70	2,75	8 x M6	12	0,8	
	42	1380	92									
55	42	1160	79									
	45	1520	88	100	23	30,5	75	3,75	8 x M6	12	1,1	
	48	1880	97									
62	48	1850	100									
	50	2200	111	110	23	30,5	86	3,75	10 x M6	12	1,3	
	52	2400	117									
68	50	2000	97									
	55	2500	106	115	23	30,5	86	3,75	10 x M6	12	1,4	
	60	3150	120									
75	55	2500	119									
	60	3200	137	138	25	32,5	100	3,75	7 x M8	30	1,7	
	65	3950	155									
80	60	3200	124									
	65	3900	140	145	25	32,5	100	3,75	7 x M8	30	1,9	
	70	4600	158									
85	65	4800	175									
	70	6100	195	155	30	39,0	114	4,50	10 x M8	30	3,5	
	75	7400	216									
90	65	4750	170									
	70	6000	190	155	30	39,0	114	4,50	10 x M8	30	3,3	
	75	7250	210									
100	70	6900	195									
	75	7500	220	170	34	44,0	124	5,00	12 x M8	30	4,7	
	80	9000	240									
110	75	7200	229									
	80	9000	252	185	39	50,0	136	5,50	9 x M10	59	5,9	
	85	10800	262									
115	80	7400	235									
	85	9200	259	188	39	50,0	141	5,50	9 x M10	59	5,5	
	90	11100	269									
120	80	10600	285									
	85	13300	314	215	42	54,0	160	6,00	12 x M10	59	9	
	90	14500	340									
125	85	11000	296									
	90	13000	324	215	42	54,0	160	6,00	12 x M10	59	8,3	
	95	15000	352									
130	90	11300	304									
	95	13300	333	215	42	54,0	160	6,00	12 x M10	59	8	
	100	15400	362									
140	95	15100	367									
	100	17600	396	230	46	60,5	175	7,25	10 x M12	100	10	
	105	20100	425									
155	105	22000	447									
	110	25000	478	265	50	64,5	192	7,25	12 x M12	100	15	
	115	28000	509									
160	110	22600	460									
	115	25700	490	265	50	64,5	192	7,25	12 x M12	100	14,5	
	120	28800	520									
165	115	31000	595									
	120	35000	630	290	56	71,0	210	7,50	8 x M16	250	22	
	125	39000	655									

18,8

To be continued...

Shrink disc standard version
TLK 603

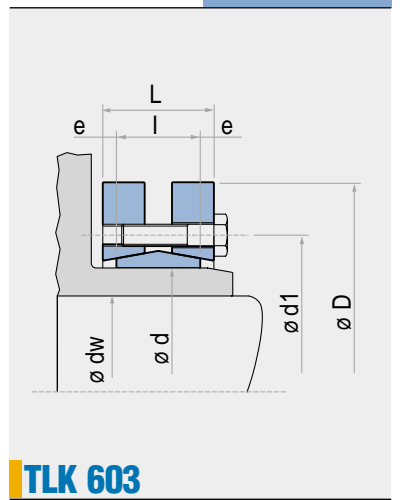

Type	Shaft diameter		Torque Mt Nm	Axial Thrust F ass. KN	Dimensions					Tightening screws DIN 931-10.9 N° x type	Tightening torque Ms Nm	Weight kg
	d mm	dw mm			D mm	I mm	L mm	d1 mm	e mm			
170	120	31900	610									
	125	36000	640	290	56	71	210	7,5	8 x M16	250	21	
	130	40100	670									
175	125	36000	605									
	130	41000	639	300	56	71	220	7,5	8 x M16	250	22	
	135	45000	675									
180	130	37000	800									
	135	42200	840	300	56	71	220	7,5	8 x M16	250	21	
	140	46300	885									
185	135	52000	778									
	140	57000	819	330	71	86	236	7,5	10 x M16	250	37	
	145	62000	861									
190	140	53500	800									
	145	58700	840	330	71	86	236	7,5	10 x M16	250	36	
	150	63800	885									
195	140	65000	933									
	150	76000	1025	350	71	86	246	7,5	12 x M16	250	41	
	155	81500	1071									
200	150	74000	990									
	155	80000	1035	350	71	86	246	7,5	12 x M16	250	41	
	160	86000	1080									
220	160	95000	1190									
	165	102000	1239	370	88	104	270	8,0	15 x M16	250	54	
	170	110000	1290									
240	170	120000	1464									
	180	138000	1576	405	92	109	295	8,5	12 x M20	490	67	
	190	156000	1675									
260	190	164000	1760									
	200	184000	1880	430	103	120	321	8,5	14 x M20	490	82	
	210	205000	2010									
280	210	217000	2090									
	220	244000	2220	460	114	134	346	10,0	16 x M20	490	102	
	230	270000	2350									
300	230	275000	2431									
	240	295000	2567	485	122	142	364	10,0	18 x M20	490	118	
	245	315000	2636									
320	240	312000	2647									
	250	340000	2786	520	122	142	386	10,0	20 x M20	490	131	
	260	374000	2900									
340	250	390000	3119									
	260	422500	3249	570	134	156	408	11,0	24 x M20	490	186	
	270	460000	3400									
350	270	442000	3276									
	280	480000	3430	580	140	162	432	11,0	24 x M20	490	195	
	285	500000	3500									
360	280	463000	3310									
	290	502000	3461	590	140	162	432	11,0	24 x M20	490	204	
	295	522000	3536									
380	290	567000	3910									
	300	610000	4080	645	144	168	458	12,0	20 x M24	840	239	
	310	658000	4248									
390	300	624000	4160									
	310	671000	4330	660	144	168	468	12,0	21 x M24	840	260	
	320	718000	4484									
400	315	670000	4260									
	320	695000	4345	680	144	168	480	12,0	21 x M24	840	280	
	330	744000	4500									
420	330	780000	4850									
	340	840000	5040	690	164	188	504	12,0	24 x M24	840	316	
	350	900000	5220									
440	340	806000	4740									
	350	860000	4910	750	177	202	527	12,5	24 x M24	840	408	
	360	917000	5090									
460	360	1000000	5670									
	370	1070000	5860	770	177	202	547	12,5	28 x M24	840	420	
	380	1140000	6050									
480	380	1170000	6150									
	390	1240000	6350	800	188	213	570	12,5	30 x M24	840	505	
	400	1310000	6550									

For larger diameter please contact us

Shrink disc heavy version TLK 602

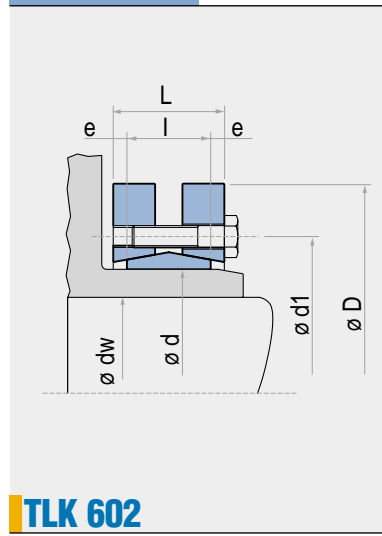

Type	Shaft diameter		Torque	Axial Thrust	Dimensions					Tightening screws DIN 931-10.9	Tightening torque	Weight
	d mm	dw mm			Mt Nm	F ass. KN	D mm	l mm	L mm			
125	85	90	15000	355	215	55	65	160	5	10 x M12	100	11
	90	17500	388									
	95	20000	422									
140	95	100	20600	433	230	60	74	175	7	12 x M12	100	13
	100	23500	469									
	105	26500	500									
155	105	110	28600	550	265	66	80	198	7	15 x M12	100	20
	110	32500	590									
	115	36400	630									
165	115	120	41000	740	290	72	88	210	8	10 x M16	250	26
	120	46000	785									
	125	50700	815									
175	125	130	47000	750	300	72	88	220	8	10 x M16	250	29
	130	52000	795									
	135	57000	840									
185	135	140	72000	1100	330	92	112	236	10	14 x M16	250	47
	140	78000	1150									
	145	86000	1200									
195	140	150	75000	1075	350	92	112	246	10	14 x M16	250	53
	150	88000	1180									
	155	96000	1235									
200	145	150	85000	1170	350	92	112	246	10	15 x M16	250	50
	150	92500	1230									
	155	100000	1290									
220	160	165	127000	1590	370	114	134	270	10	20 x M16	250	65
	165	136000	1650									
	170	146500	1720									
240	170	180	155000	1820	405	120	144	295	12	15 x M20	490	87
	180	176000	1960									
	190	198000	2080									
260	190	200	213000	2260	430	136	160	321	12	18 x M20	490	100
	200	240000	2420									
	210	268000	2580									
280	210	220	285000	2740	460	148	172	346	12	21 x M20	490	132
	220	320000	2910									
	230	355000	3090									
300	230	240	341000	2960	485	152	176	364	12	22 x M20	490	140
	240	376000	3130									
	245	394000	3215									
320	240	250	378000	3150	520	160	184	386	12	24 x M20	490	165
	250	415000	3325									
	260	451000	3470									
340	250	260	489500	3910	570	176	200	420	12	21 x M24	840	240
	260	530000	4075									
	270	578000	4275									
350	270	280	556000	4122	580	176	200	425	12	21 x M24	840	247
	280	604000	4320									
	285	629000	4415									
360	280	290	612000	4370	590	180	204	432	12	22 x M24	840	250
	290	663000	4570									
	295	689000	4670									
380	290	300	618000	4270	645	180	204	458	12	22 x M24	840	320
	300	668000	4455									
	310	719000	4645									
390	300	310	708000	4715	660	188	212	468	12	24 x M24	840	350
	310	762000	4910									
	320	814500	5090									
400	315	320	765000	4855	680	188	212	480	12	24 x M24	840	370
	320	788000	4927									
	330	845000	5125									
420	330	340	999000	6055	690	214	238	504	12	30 x M24	840	410
	340	1068000	6285									
	350	1140000	6515									
440	340	350	1058000	6230	750	224	252	527	14	24 x M27	1250	525
	350	1130000	6460									
	360	1204000	6690									
460	360	370	1320000	7440	770	224	252	547	14	28 x M27	1250	540
	370	1420000	7700									
	380	1500000	7950									

For larger diameter please contact us.

Shrink disc light version TLK 601

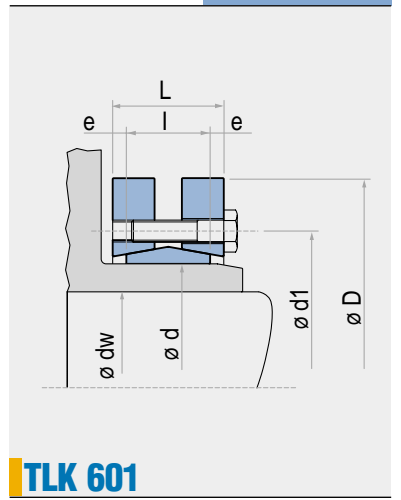

Type	Shaft diameter		Torque	Axial Thrust	Dimensions					Tightening screws DIN 931-10.9	Tightening torque	Weight
	d mm	dw mm			Mt Nm	F ass. KN	D mm	l mm	L mm			
125	95	100	10550	220	185	39	51	158	6	8 x M10	59	6
	100	12100	240									
	105	13800	260									
140	110	120	14800	265	220	39	51	175	6	9 x M10	59	8
	120	18640	310									
	125	20500	325									
155	130	135	24000	365	245	39	51	192	6	11 x M10	59	10
	135	26400	390									
	140	29000	410									
165	135	140	32000	475	260	46	62	210	8	10 x M12	100	14
	140	35200	500									
	145	38500	530									
175	145	150	39000	535	275	46	62	220	8	11 x M12	100	16
	150	42400	560									
	155	46000	590									
185	155	160	46600	600	295	46	62	225	8	12 x M12	100	20
	160	50300	625									
	165	54000	650									
195	165	170	63000	760	315	56	72	237	8	15 x M12	100	27
	170	67700	795									
	175	72500	825									
200	175	180	74000	850	330	56	72	242	8	16 x M12	100	30
	180	79500	890									
	185	84500	915									
220	180	190	82800	920	345	66	84	265	9	10 x M16	250	35
	190	93500	980									
	200	105000	1055									
240	200	210	113000	1135	370	66	84	290	9	12 x M16	250	44
	210	127500	1210									
	215	134500	1250									
260	220	230	149000	1350	395	72	92	310	10	14 x M16	250	48
	230	165000	1435									
	235	173000	1475									
280	230	240	171000	1485	425	84	104	333	10	16 x M16	250	60
	240	189000	1570									
	250	208000	1660									
300	250	260	215000	1720	460	84	104	358	10	18 x M16	250	75
	260	234000	1800									
	270	255000	1890									
320	270	280	260000	1940	495	84	106	378	11	20 x M16	250	84
	280	284000	2030									
	290	306000	2125									
340	290	300	300000	2070	535	84	106	402	11	21 x M16	250	100
	300	324400	2160									
	305	337000	2210									
350	300	310	372000	2485	545	100	122	413	11	16 x M20	490	120
	305	385000	2540									
	310	400000	2590									
360	300	310	360000	2400	555	100	122	423	11	16 x M20	490	125
	310	388000	2500									
	320	415000	2590									
380	320	325	435000	2720	585	112	136	442	12	18 x M20	490	150
	325	451000	2780									
	330	467000	2835									
390	330	340	505000	3060	595	112	136	452	12	20 x M20	490	156
	340	540000	3175									
	350	577000	3295									
400	340	350	550000	3235	615	112	136	462	12	21 x M20	490	170
	350	587000	3360									
	360	626000	3480									
420	350	360	578000	3300	630	120	144	485	12	22 x M20	490	185
	360	617000	3425									
	370	655000	3545									
440	370	380	677000	3660	660	120	144	505	12	24 x M20	490	205
	380	719000	3785									
	390	762000	3910									
460	390	400	840000	4320	685	132	158	527	13	28 x M20	490	235
	400	890000	4460									
	410	935000	4580									

For larger diameter please contact us.

Shrink discs

TLK 622 • TLK 623 • TLK 681 • TLK 683

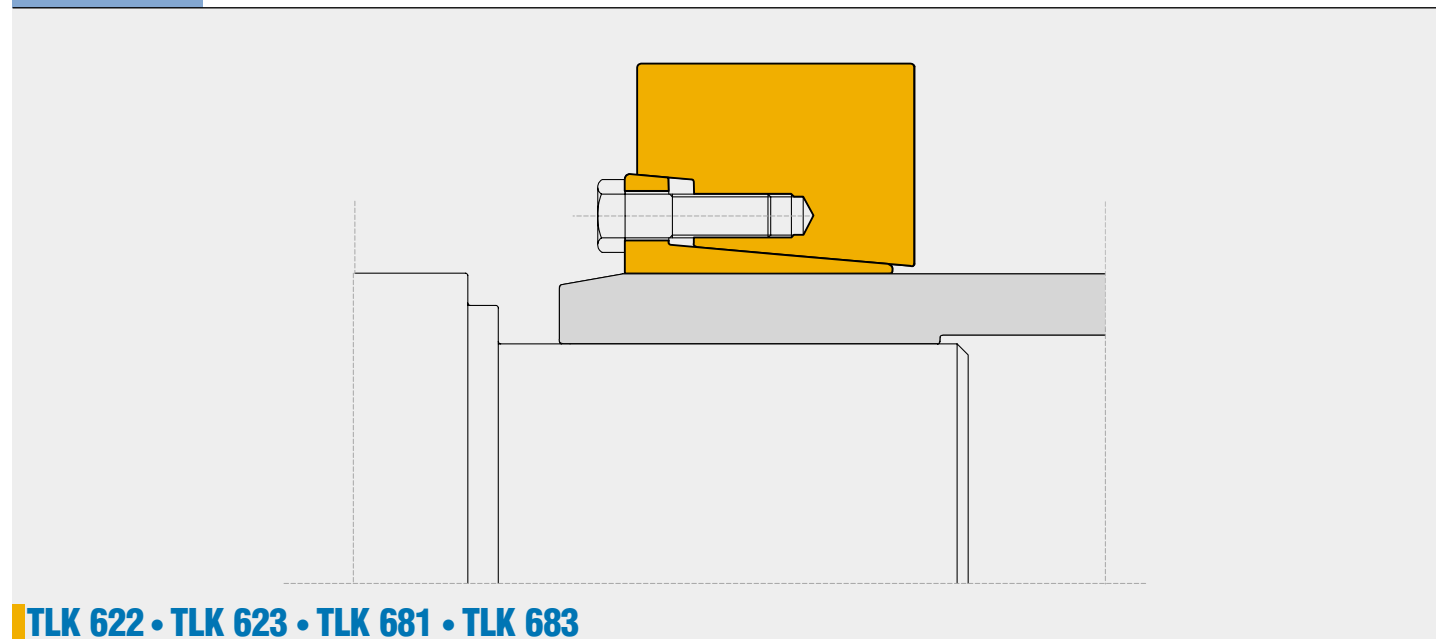

TLK 622 • TLK 623 • TLK 681 • TLK 683

Characteristics

- Very high torques
- No shaft-hub axial movement
- Limited installation time
- Quick dismantling

Installation

Carefully clean the hub and shaft contact surfaces. Slide the shrink disc outside the hollow shaft. Tighten gradually and regularly in continuous sequence all screws to reach the tightening torque **Ms** indicated in the table. To reach the required tightening torque **Ms** it is necessary to repeat the procedure more than once. Do not use **molybdenum bisulphide** in the hub and shaft contact surfaces.

Dismantling

Loosen the clamping screws in a continuous and gradual sequence. Do not remove screws from threads. Normally with this operation the shrink disc is released. In case of reuse, apply a solid lubricant (that can guarantee a friction coefficient equal to 0,04) in the screws and in the tapered surfaces.

Tolerances, surface finish

A good surface finish by machine tool is sufficient. Maximum allowable surface finish:
Rt max 16 µm (Ra 3 µm - Rz 13 µm)

Maximum permissible tolerances:
d = f7 for shaft

Dw diameter tolerances

dw: Up to 150 mm H7/h6
From 155 mm H7/g6

Axial movement

During screws tightening the hub has no axial movement with respect to the shaft.

Shrink discs

TLK 622 • TLK 681

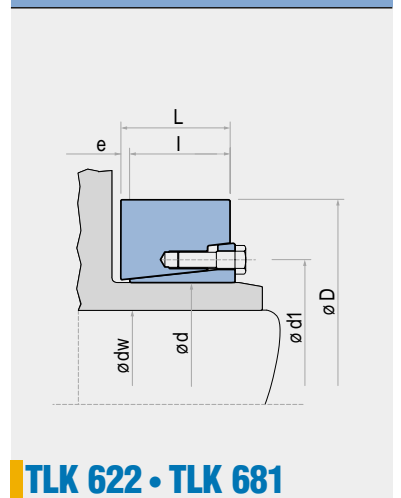

TLK 622 • TLK 681

Type	Shaft diameter	TLK 622			TLK 681			Dimensions					Tightening screws DIN 931	Weight Kg
		Torque	Axial Thrust	Tightening torque	Torque	Axial Thrust	Tightening torque	D	I	L	d1	e		
d mm	dw mm	Mt Nm	F ass. KN	Ms Nm	Mt Nm	F ass. KN	Ms Nm	D mm	I mm	L mm	d1 mm	e mm		
12	9	20	5	-	-	-	-	35	10	11	24	1	M6	0,1
	11	30	6	-	-	-	-							
14	12	50	9	12	-	-	-	38	10	11	26	1	M6	0,1
	13	70	10	-	-	-	-							
16	14	90	13	12	-	-	-	41	13,5	15	28	1,5	M6	0,1
	15	80	11	-	-	-	-							
18	16	110	14	12	-	-	-	44	13,5	15	30	1,5	M6	0,1
	17	150	18	-	-	-	-							
20	18	180	20	12	-	-	-	47	13,5	15	32	1,5	M6	0,1
	19	160	17	-	-	-	-							
24	20	210	20	12	-	-	-	50	16	18	36	2	M6	0,2
	22	280	25	-	-	-	-							
30	24	270	23	-	-	-	-	60	18	20	44	2	M6	0,3
	25	320	25	12	-	-	-							
	26	360	28	-	-	-	-							
36	30	610	41	30	-	-	-	72	20	22	52	2	M8	0,5
	33	820	50	-	-	-	-							
44	34	690	41	-	-	-	-	80	22	24	61	2	M8	0,6
	35	770	44	30	-	-	-							
	37	920	50	-	-	-	-							
50	38	1110	58	-	1500	78	-	90	23,5	26	68	2,5	M8	0,8
	40	1290	65	30	1700	85	35							
	42	1510	71	-	1900	93	-							
55	42	1230	59	-	1600	78	-	100	26	29	72	3	M8	1,1
	45	1530	68	30	2000	88	35							
	48	1860	78	-	2400	99	-							
62	48	1670	70	-	2200	91	-	110	26	29	80	3	M8	1,3
	50	1890	76	30	2400	98	35							
	52	2120	81	-	2700	104	-							
68	50	1870	75	-	2400	94	-	115	26	29	86	3	M8	1,3
	55	2450	89	30	3000	111	35							
	60	3120	104	-	3800	127	-							
75	55	2330	85	-	3700	136	-	138	27	31	100	4	M10	2,3
	60	3020	101	59	4700	157	70							
	65	3810	117	-	5800	178	-							
80	60	3190	106	-	4200	142	-	141	27	31	104	4	M10	2,3
	65	4060	123	59	5200	161	70							
	70	4910	140	-	6300	181	-							
90	65	5400	166	-	5900	181	-	155	34	38	114	4	M10	3,2
	70	6500	187	59	7100	203	70							
	75	7800	208	-	8500	226	-							
100	70	6000	171	-	7400	213	-	170	39	43	124	4	M10	4,3
	75	7200	192	59	8900	237	70							
	80	8500	213	-	10400	261	-							
110	80	10000	249	-	12600	314	-	185	43,5	49	138	5,5	M12	5,8
	85	11700	275	100	14600	344	121							
	90	13600	302	-	16900	375	-							
120	85	11900	280	-	13600	320	-	197	46,5	53	147	6,5	M12	6,9
	90	13800	307	100	15700	349	121							
	95	15900	334	-	18000	378	-							
125	90	14400	319	-	16400	365	-	215	46,5	53	152	6,5	M12	8,7
	95	16500	347	100	18800	395	121							
	100	18700	375	-	21300	426	-							
135	95	18100	382	-	20300	427	-	230	49,5	58	165	8,5	M14	11
	100	20600	412	160	23000	459	195							
	110	26000	473	-	28900	525	-							
140	100	19600	392	-	23000	459	-	230	49,5	58	170	8,5	M14	10
	105	22100	421	160	25800	492	195							
	115	27600	481	-	32100	558	-							
155	110	26500	482	-	31100	565	-	263	53,5	62	184	8,5	M14	15
	115	29500	514	160	34500	601	195							
	125	36100	578	-	42000	672	-							
165	120	37300	622	-	44000	734	-	290	58	68	198	10	M16	22
	125	41200	659	250	48500	776	300							
	135	49600	734	-	58100	860	-							
175	130	45000	692	-	54000	834	-	300	58	68	208	10	M16	23
	135	49000	730	250	59000	876	300							
	145	58000	805	-	70000	962	-							

To be continued...

Shrink discs TLK 622 • TLK 681

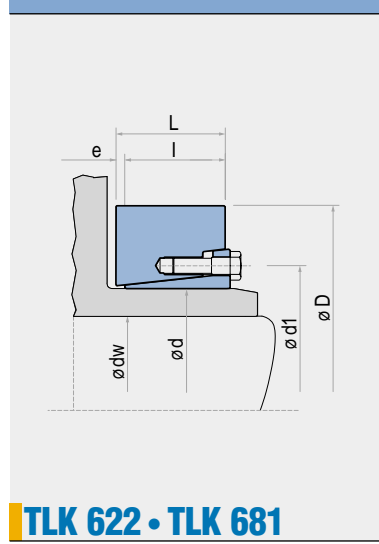

TLK 622

TLK 681

Type	Shaft diameter	Torque			Tightening torque			Dimensions					Tightening screws DIN 931	Weight Kg	
		Mt Nm	F ass. KN	Ms Nm	Mt Nm	F ass. KN	Ms Nm	D mm	I mm	L mm	d1 mm	e mm			
185	140	64000	916		81000	1157									
	145	70000	961	250	88000	1210									
	155	82000	1053		102000	1319									
200	150	81000	1073		96000	1279									
	155	87000	1120	250	103000	1333	300	340	75	85	238	10	M16	36	
	165	100000	1216		119000	1442									
220	160	103000	1283		129000	1615									
	170	119000	1395	490	149000	1749	570	370	91	103	268	12	M20	53	
	180	136000	1509		169000	1883									
240	170	122000	1439		151000	1773									
	180	140000	1555	490	172000	1909	570	405	94	107	288	13	M20	66	
	200	179000	1790		218000	2183									
260	190	163000	1715		212000	2231									
	200	184000	1842	490	238000	2385	570	430	105	119	312	14	M20	82	
	220	231000	2099		297000	2696									
280	210	215000	2051		279000	2661									
	220	240000	2186	490	311000	2825	570	460	116	132	334	16	M20	103	
	240	295000	2458		379000	3156									
300	220	270000	2456		332000	3018									
	230	300000	2605	840	367000	3193	980	485	124	140	360	16	M24	120	
	250	363000	2906		443000	3545									
320	240	301000	2511		404000	3370									
	250	332000	2655	840	444000	3549	980	520	124	140	380	16	M24	138	
	270	398000	2945		528000	3911									
340	250	390000	3118		488000	3905									
	260	427000	3283	840	533000	4101	980	570	137	155	402	18	M24	189	
	280	506000	3617		630000	4498									
350	270	493000	3649		616000	4563									
	280	535000	3825	840	669000	4778	980	580	142	162	414	20	M24	202	
	290	580000	4001		725000	5000									
360	270	496000	3676		625000	4628									
	280	539000	3852	840	677000	4839	980	590	142	162	424	20	M24	207	
	300	631000	4206		790000	5264									
380	290	585000	4034		725000	5000									
	300	632000	4215	1250	783000	5220	1450	640	146	166	454	20	M27	244	
	310	681000	4397		844000	5445									
390	290	640000	4411		781000	5384									
	300	691000	4605	1250	842000	5611	1450	650	146	166	454	20	M27	249	
	320	799000	4996		971000	6069									
420	320	742000	4640		969000	6057									
	330	797000	4829	1250	1038000	6290	1450	670	166	186	486	20	M27	285	
	350	912000	5209		1183000	6758									
440	340	945000	5557		1212000	7128									
	350	1009000	5764	1250	1292000	7382	1450	720	174	194	506	20	M27	357	
	370	1143000	6181		1460000	7891									
460	360	1104000	6133		1393000	7739									
	370	1174000	6345	1250	1479000	7995	1450	770	174	194	534	20	M27	419	
	390	1320000	6771		1660000	8511									
480	380	1300000	6843		1657000	8721									
	390	1378000	7066	1640	1754000	8993	1970	800	191	213	552	22	M30	492	
	410	1541000	7516		1956000	9542									
500	400	1496000	7478		1887000	9435									
	410	1581000	7711	1640	1992000	9717	1970	850	191	213	572	22	M30	567	
	430	1759000	8180		2211000	10283									
530	430	1930000	8976		2397000	11150									
	440	2031000	9234	1640	2521000	11459	1970	910	216	238	606	22	M30	744	
	460	2243000	9752		2778000	12078									
560	450	2097000	9318		2545000	11313									
	460	2201000	9572	1640	2671000	11611	1970	940	216	238	632	22	M30	776	
	480	2420000	10081		2930000	12210									
590	470	2593000	11032		2969000	12636									
	480	2715000	11314	1640	3108000	12952	1970	960	235	260	664	25	M30	835	
	500	2970000	11881		3397000	13587									
620	500	2904000	11616		3402000	13608									
	520	3169000	12190	1640	3708000	14261	1970	1020	261	286	706	25	M30	1064	
	540	3447000	12767		4028000	14918									

For larger diameter please contact us

Shrink discs TLK 623 • TLK 683

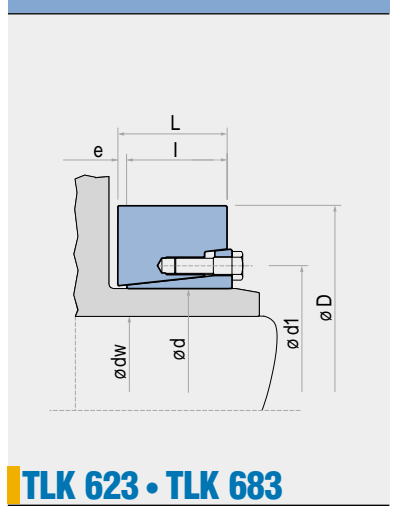

TLK 623

TLK 683

Type	Shaft diameter	Torque			Tightening torque			Dimensions					Tightening screws DIN 931	Weight Kg	
		Mt Nm	F ass. KN	Ms Nm	Mt Nm	F ass. KN	Ms Nm	D mm	I mm	L mm	d1 mm	e mm			
140	100	26000	523		30000	607									
	105	30000	562	250	34000	650	300	230	64	74	174	10	M16	13	
	115	37000	641		42000	737									
155	110	36000	646		45000	810									
	115	40000	687	250	49000	860	300	263	70	80	194	10	M16	19	
	125	48000	772		60000	959									
165	120	50000	828		63000	1047									
	125	55000	877	250	69000	1105	300	290	77	88	204	11	M16	26	
	135	66000	977		83000	1223									
175	130	61000	943		73000	1121									
	135	67000	993	250	80000	1178	300	300	77	88	214	11	M16	27	
	145	79000	1094		94000	1292									
185	140	89000	1269		106000	1512									
	145	96000	1330	490	115000	1582	570	320	100	112	232	12	M20	40	
	155	113000	1455		134000	1723									
200	150	104000	1391		126000	1685									
	155	113000	1453	490	136000	1757	570	340	100	112	246	12	M20	44	
	165	130000	1577		157000	1900									
220	160	127000	1591		162000	2027									
	165	137000	1661	490	174000	2112	570	370	121	134	266	13	M20	64	
	180	169000	1876		213000	2366									
240	170	157000	1847		206000	2424									
	180	180000	1996	490	235000	2607	570	405	130	144	286	14	M20	81	
	200	230000	2300		298000	2978									
260	190	230000	2424		285000	3000									
	200	260000	2600	490											

Locking Assemblies

Calculation of minimum hub diameter DM

By installing TOLLOK locking assemblies the surface pressure **Pn**, existing between the clamping outer ring and related hub bore, generate a stress. To calculate the minimum hub diameter **DM** the formula normally used for thick hollow cylinder is valid. Depending from hub shape and length with respect to the dimension **L1** of locking assemblies, the real stresses change.

Factor C must be considered in function of application type.

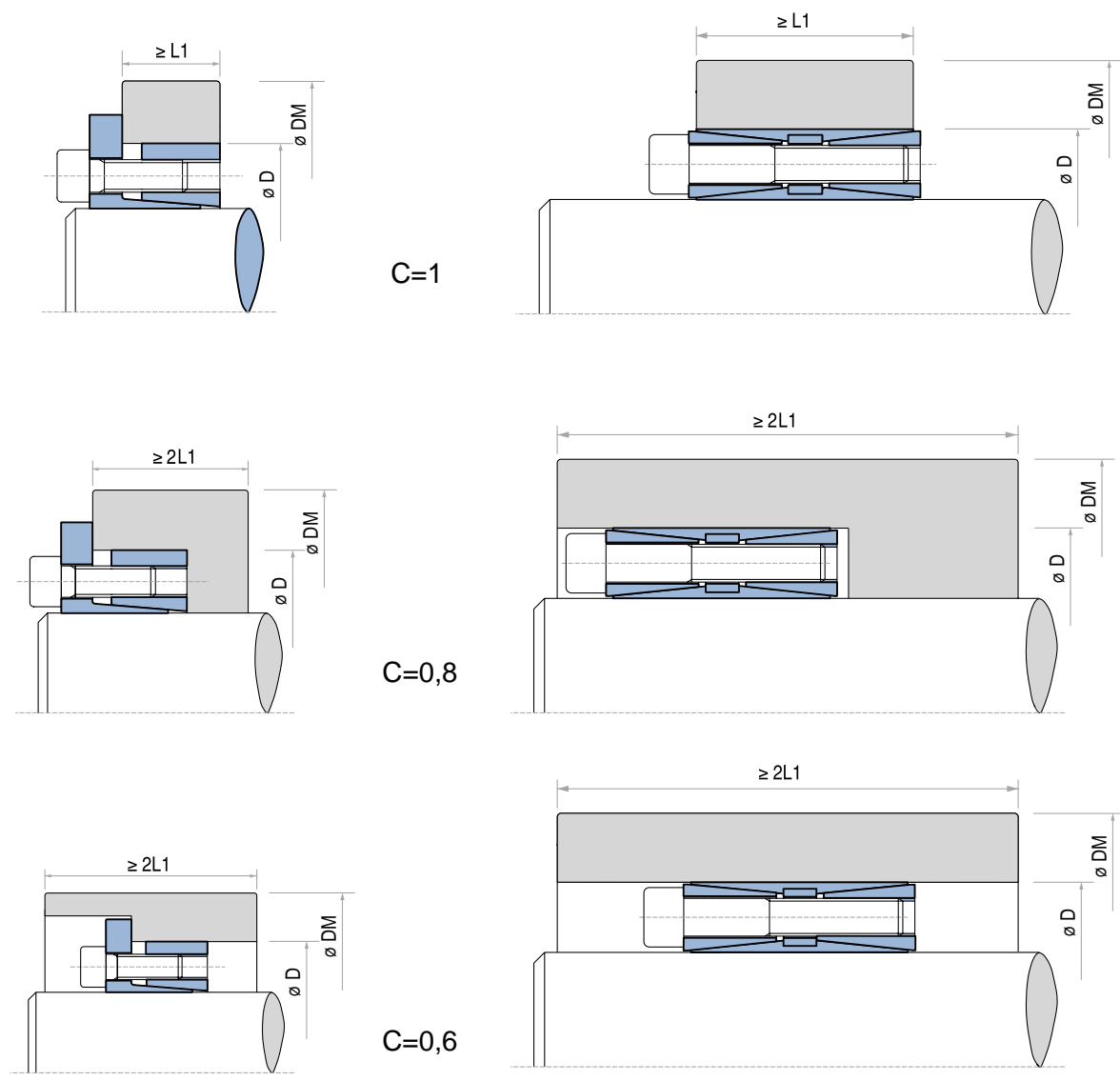

For minimum hub diameter DM calculation following formula must be applied:

$$DM \geq D \cdot K$$

where K is equal to:
$$K = \sqrt{\frac{\sigma_{02} + (C \cdot Pn)}{\sigma_{02} - (C \cdot Pn)}}$$

To simplify the calculation our technical department has prepared the table on page 39.

Example:
 Locking Assembly type TOLLOK TLK 131 ø 60x90.
 Hub pressure Pn = 85 N/mm² (see table page 9).
 Hub material GGG40 (yielding limit $\sigma_{02} = 250$ N/mm²).
 Hub length and shape equivalent C = 1.

$$DM \geq 90 \cdot 1,42 \geq 127,8 \text{ mm}$$

Locking Assemblies

Calculation of minimum hub diameter DM

TABLE OF COEFFICIENT K

Pressure generated on the hub pn N/mm ²	Application type C	σ_{02} Yield point N/mm ²											
		150	180	200	220	250	270	300	350	400	450	600	
		Material type											
		GG20	GG25 GS38	GG30 GTS35	GS45 ST37-2	GGG40 GS52	ST50-2 C35	GGG50 GS60 ST60-2	GGG60 GS62 ST70-2	GGG70 GS70 C60			
60	C = 0,6	1,28	1,25	1,20	1,18	1,15	1,14	1,12	1,10	1,09	1,08	1,06	
	C = 0,8	1,39	1,30	1,24	1,23	1,22	1,20	1,18	1,15	1,12	1,11	1,08	
	C = 1	1,52	1,42	1,36	1,32	1,28	1,25	1,22	1,18	1,16	1,14	1,10	
65	C = 0,6	1,30	1,25	1,22	1,20	1,18	1,15	1,13	1,11	1,10	1,09	1,07	
	C = 0,8	1,44	1,35	1,30	1,28	1,24	1,22	1,20	1,16	1,14	1,12	1,09	
	C = 1	1,60	1,45	1,40	1,35	1,30	1,28	1,24	1,20	1,18	1,16	1,12	
70	C = 0,6	1,34	1,26	1,24	1,22	1,18	1,16	1,15	1,12	1,11	1,10	1,07	
	C = 0,8	1,48	1,38	1,34	1,30	1,25	1,23	1,20	1,18	1,15	1,13	1,10	
	C = 1	1,65	1,50	1,45	1,40	1,34	1,30	1,26	1,22	1,20	1,17	1,13	
75	C = 0,6	1,30	1,28	1,25	1,23	1,20	1,18	1,16	1,14	1,12	1,11	1,08	
	C = 0,8	1,52	1,42	1,36	1,32	1,28	1,25	1,22	1,18	1,16	1,14	1,11	
	C = 1	1,74	1,55	1,48	1,42	1,36	1,33	1,30	1,25	1,20	1,18	1,13	
80	C = 0,6	1,39	1,31	1,28	1,25	1,21	1,20	1,18	1,15	1,13	1,11	1,08	
	C = 0,8	1,58	1,45	1,39	1,35	1,30	1,27	1,24	1,20	1,18	1,15	1,11	
	C = 1	1,81	1,61	1,53	1,46	1,39	1,36	1,31	1,26	1,22	1,20	1,14	
85	C = 0,6	1,42	1,34	1,30	1,27	1,23	1,21	1,19	1,16	1,14	1,12	1,09	
	C = 0,8	1,63	1,49	1,42	1,38	1,32	1,29	1,26	1,22	1,19	1,16	1,12	
	C = 1	1,90	1,67	1,57	1,50	1,42	1,39	1,34	1,28	1,24	1,21	1,15	
90	C = 0,6	1,46	1,36	1,32	1,28	1,25	1,22	1,20	1,17	1,15	1,13	1,09	
	C = 0,8	1,69	1,53	1,46	1,40	1,34	1,31	1,28	1,23	1,20	1,18	1,13	
	C = 1	2,00	1,73	1,62	1,54	1,46	1,41	1,36	1,30	1,26	1,22	1,16	
95	C = 0,6	1,49	1,39	1,34	1,30	1,26	1,24	1,21	1,18	1,15	1,14	1,10	
	C = 0,8	1,75	1,57	1,49	1,43	1,37	1,34	1,30	1,25	1,21	1,19	1,14	
	C = 1	2,11	1,80	1,68	1,59	1,49	1,44	1,39	1,32	1,27	1,24	1,17	
100	C = 0,6	1,53	1,41	1,36	1,32	1,28	1,25	1,22	1,19	1,16	1,14	1,11	
	C = 0,8	1,81	1,61	1,53	1,46	1,39	1,36	1,31	1,26	1,22	1,20	1,14	
	C = 1	2,24	1,87	1,73	1,63	1,53	1,48	1,41	1,34	1,29	1,25	1,18	
105	C = 0,6	1,56	1,44	1,39	1,34	1,29	1,27	1,24	1,20	1,17	1,15	1,11	
	C = 0,8	1,88	1,66	1,56	1,50	1,42	1,38	1,33	1,28	1,24	1,21	1,15	
	C = 1	2,38	1,95	1,79	1,68	1,56	1,51	1,44	1,36	1,31	1,27	1,19	
110	C = 0,6	1,60	1,47	1,41	1,36	1,31	1,28	1,25	1,21	1,18	1,16	1,12	
	C = 0,8	1,96	1,71	1,60	1,53	1,44	1,41	1,35	1,29	1,25	1,22	1,16	
	C = 1	2,55	2,04	1,86	1,73	1,60	1,54	1,47	1,38	1,33	1,28	1,20	
115	C = 0,6	1,64	1,50	1,43	1,36	1,33	1,30	1,26	1,22	1,19	1,17	1,12	
	C = 0,8	2,04	1,76	1,64	1,56	1,47	1,43	1,37	1,31	1,26	1,23	1,17	
	C = 1	2,75	2,13	1,93	1,79	1,64	1,58	1,50	1,41	1,34	1,30	1,21	
120	C = 0,6	1,69	1,53	1,46	1,40	1,34	1,31	1,28	1,23	1,20	1,18	1,13	
	C = 0,8	2,13	1,81	1,69	1,60	1,50	1,45	1,39	1,33	1,28	1,24	1,18	
	C = 1	3,00	2,24	2,00	1,84	1,69	1,61	1,53	1,43	1,36	1,31	1,22	
125	C = 0,6	1,73	1,56	1,48	1,43	1,36	1,33	1,29	1,24	1,21	1,18	1,13	
	C = 0,8	2,24	1,87	1,73	1,63	1,53	1,48	1,41	1,34	1,29	1,25	1,18	
	C = 1	3,32	2,35	2,08	1,91	1,73	1,65	1,56	1,45	1,38	1,33	1,24	
130	C = 0,6	1,78	1,59	1,51	1,45	1,38	1,35	1,30	1,25	1,22	1,19	1,14	
	C = 0,8	2,35	1,93	1,78	1,67	1,56	1,50	1,44	1,36	1,30	1,27	1,19	
	C = 1	3,74	2,49	2,17	1,97	1,78	1,69	1,59	1,48	1,40	1,35	1,25	
135	C = 0,6	1,83	1,62	1,54	1,47	1,40	1,36	1,32	1,27	1,23	1,20	1,15	
	C = 0,8	2,48	2,00	1,83	1,71	1,59	1,53	1,46	1,38	1,32	1,28	1,20	
	C = 1	4,36	2,65	2,27	2,04	1,83	1,73	1,62	1,50	1,42	1,36	1,26	
140	C = 0,6	1,88	1,66	1,56	1,50	1,42	1,38	1,33	1,28	1,24	1,21	1,15	
	C = 0,8	2,63	2,07	1,88	1,75	1,62	1,55	1,48	1,39	1,33	1,29	1,21	
	C = 1	5,39	2,83	2,38	2,12	1,88	1,78	1,66	1,53	1,44	1,38	1,27	
145	C = 0,6	1,94	1,69	1,59	1,52	1,44	1,40	1,35	1,29	1,25	1,22	1,16	
	C = 0,8	2,80	2,15	1,94	1,80	1,65	1,58	1,50	1,41	1,35	1,30	1,22	
	C = 1	7,68	3,05	2,50	2,21	1,94	1,82	1,69	1,55	1,46	1,40	1,28	
150	C = 0,6	2,00	1,73	1,62	1,54	1,46	1,41	1,36	1,30	1,26	1,23	1,16	
	C = 0,8	3,00	2,24	2,00	1,84	1,69	1,61	1,53	1,43	1,36	1,31	1,23	
	C = 1	—	3,32	2,65	2,30	2,00	1,87	1,73	1,58	1,48	1,41	1,29	
155	C = 0,6	2,06	1,77	1,65	1,57	1,48	1,43	1,38	1,31	1,27	1,24	1,17	
	C = 0,8	3,25	2,33	2,06	1,89	1,72	1,65	1,55	1,45	1,38	1,33	1,23	
	C = 1	—	3,66	2,80	2,40	2,06	1,92	1,77	1,61	1,51	1,43	1,30	
160	C = 0,6	2,13	1,81	1,69	1,60	1,50	1,45	1,39	1,33	1,28	1,24	1,18	
	C = 0,8	3,55	2,43	2,13	1,94	1,76	1,67	1,58	1,47	1,39	1,34	1,24	
	C = 1	—	4,12	3,00	2,52	2,13	1,98	1,81	1,64	1,53	1,45	1,31	
165	C = 0,6	2,21	1,86	1,72	1,62	1,52	1,47	1,41	1,34	1,29	1,25	1,18	
	C = 0,8	3,96	2,55	2,21	2,00	1,80	1,71	1,60	1,49	1,41	1,35	1,25	
	C = 1	—	4,80	3,23	2,65	2,21	2,04	1,86	1,67	1,55	1,47	1,33	



TOLLOK®

Viale Adriatico, 9
44020 Masi Torello (Ferrara) • Italy
Tel. +39.0532.816911
Fax +39.0532.819020

e-mail: tollok@tollok.com
www.tollok.com

*Mod. 1016 - 01/03/2003 - This publication cancels and replaces all previous editions.
To improve the results TOLLOK S.p.A. reserves the right to modify the project's dimensions and all data indicated in this catalogue.*

The publication the copying even partial of the catalogue's content without TOLLOK S.p.A. written authorization is forbidden.