

Sorting

- high cycling frequency
- short response time
- long life
- control from vision system

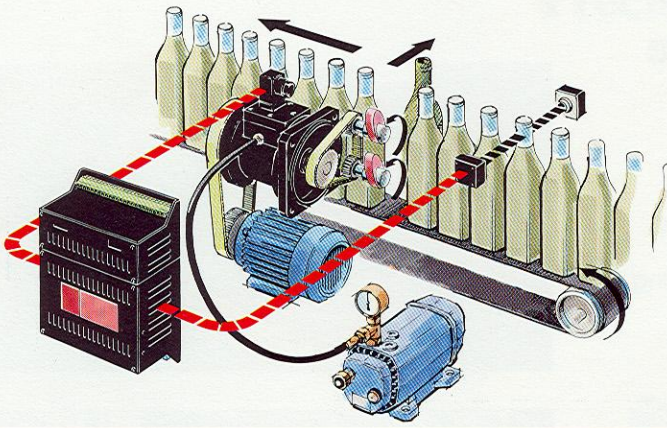

Linear feeding

- high positioning accuracy
- simple switching
- no error accumulation
- control based on counter and/or registration mark detection

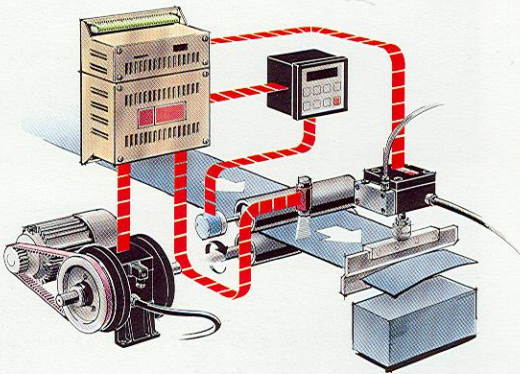

Rotary knife

- continuous material feed
- quick length adjustment
- high cycling frequency
- control based on counter

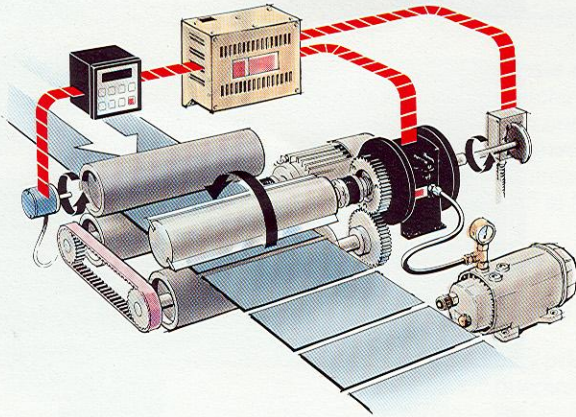

Microprocessor-controlled positioning

- a built-in microprocessor makes it possible to handle difficult control tasks

