

PTO Clutch



The Hilliard PTO Clutch is chosen for most start and stop applications that require positive engagement/disengagement and overload protection. The clutch mounts directly on the engine shaft and has a yoke-style engagement system. The clutch is typically mounted in a rugged cast housing with an oil sump.

How The Design Works

The input side of the PTO clutch is designed to mount to the engine or motor shaft which allows the driving power source to transmit full torque to the driven device.

The output side of the clutch is a splined bore directly mounted to a gearbox or jackshaft with bearing support.

The clutch can be engaged and disengaged either by hand or remotely using a cylinder. (Cylinder supplied by customer.)

The driven equipment can be started with a slow or rapid engagement and the operator has full control of the speed.

An over center cam design holds the clutch engaged or disengaged.

Torque is easily adjusted by rotating the outer housing adjusting ring.

The Hilliard design incorporates very few parts and no linkage that can wear out, making it more reliable.

The PTO Clutch is a 4-1/2" locking, over-center clutch.

Advantages and Benefits

- Reliable, Long Life
- Full Control of Clutch Engagement
- Can be Used with Multiple Power Sources
- Adjustable Torque Setting
- Simplified No Linkage Design
- Bearing Engagement Collar
- Rebuildable Unit



Specifications

Torque: 20-45 lb.ft. Max.
Speed: 3800 RPM
HP: 13 Max.
Bore Sizes: 1", 1-1/8"

Applications*

- Plaster Gun
- Mortar/Concrete Mixers
- Cable Winches
- Stationary Power Units
- Portable Sawmill
- Trailer-Mounted Power Equipment

* For diesel applications, send engine torque curves to Hilliard to determine if PTO clutch is applicable.

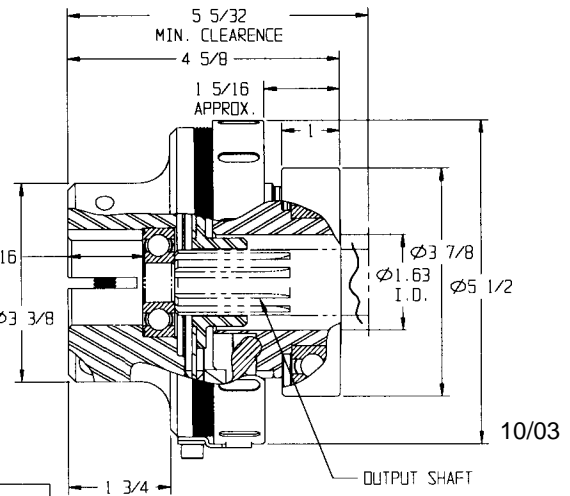
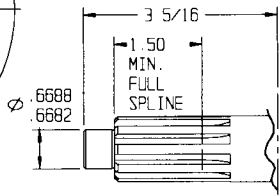
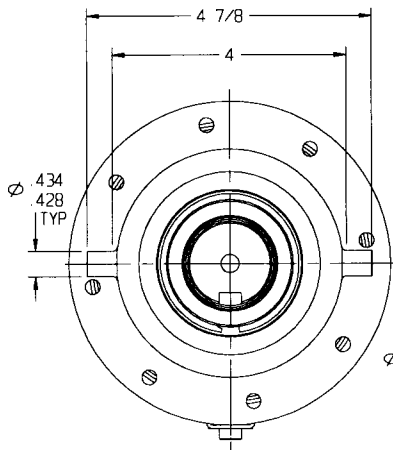
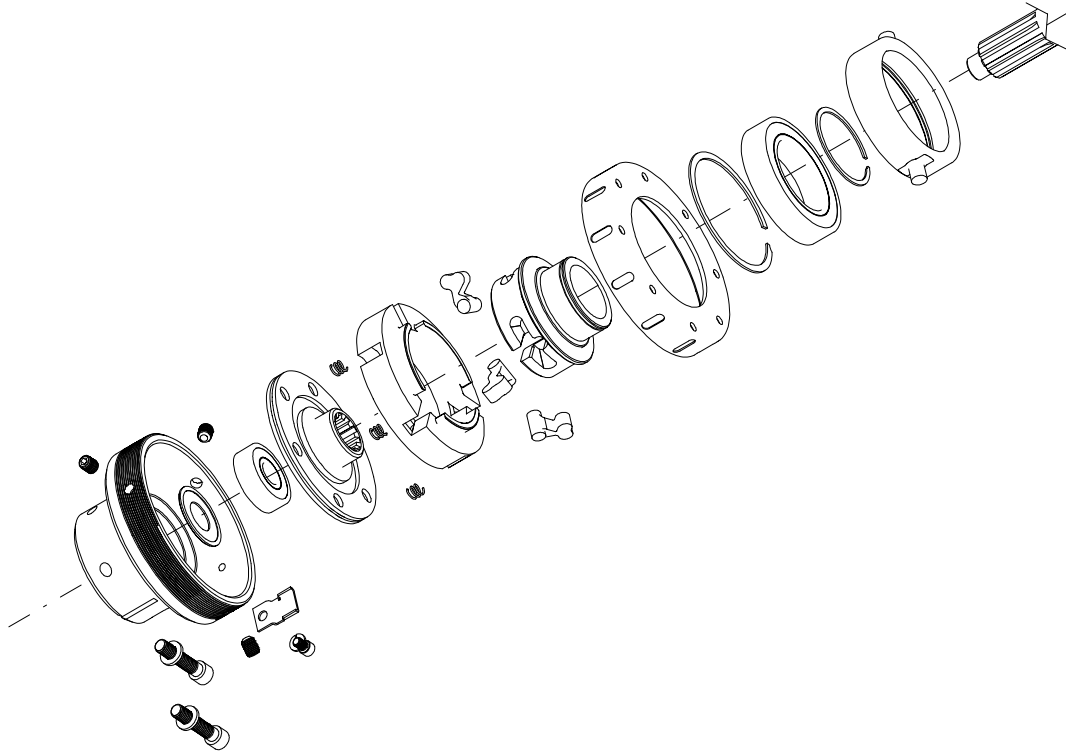

CLUTCH BORE SIZES	
BORE DIA.	KEYWAY
1.000/1.001	1/4 X 1/8
1.125/1.126	1/4 X 1/8

	SPLINE DATA (STRAIGHT SIZED 10 TOOTH)	
	INTERNAL	EXTERNAL
MAJOR DIA.	1.152/1.138	1.1235/1.1225
MINOR DIA.	.952/.938	.910/.850

PTO Clutch Assembly The Hilliard Corporation reserves the right to change specifications and dimensions at any time. Please contact the factory for the most current information.

INDUSTRIAL CLUTCH PARTS LTD

Unit 11 Bingswood Industrial Estate
 Whaley Bridge
 United Kingdom SK23 7LY
<http://www.industrialclutch.com>

