

Serie 501..WD

GOIZPER

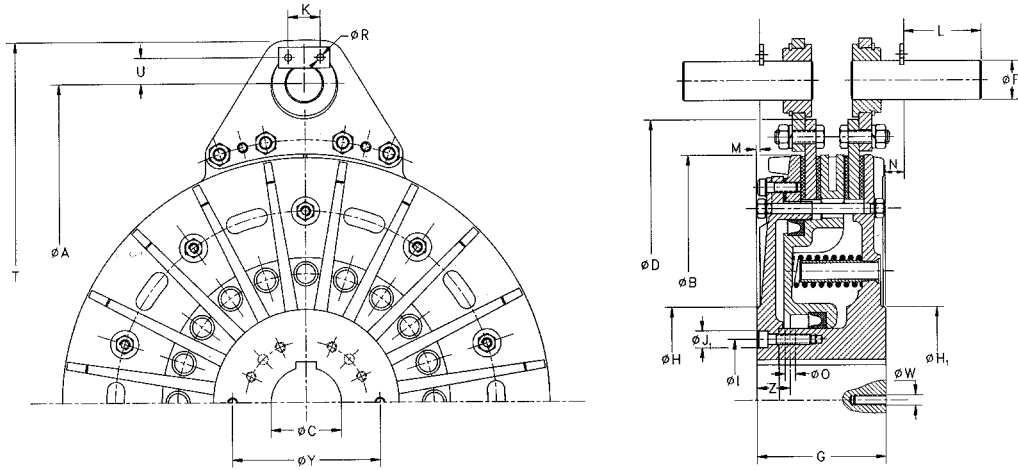

Serie 502..WD

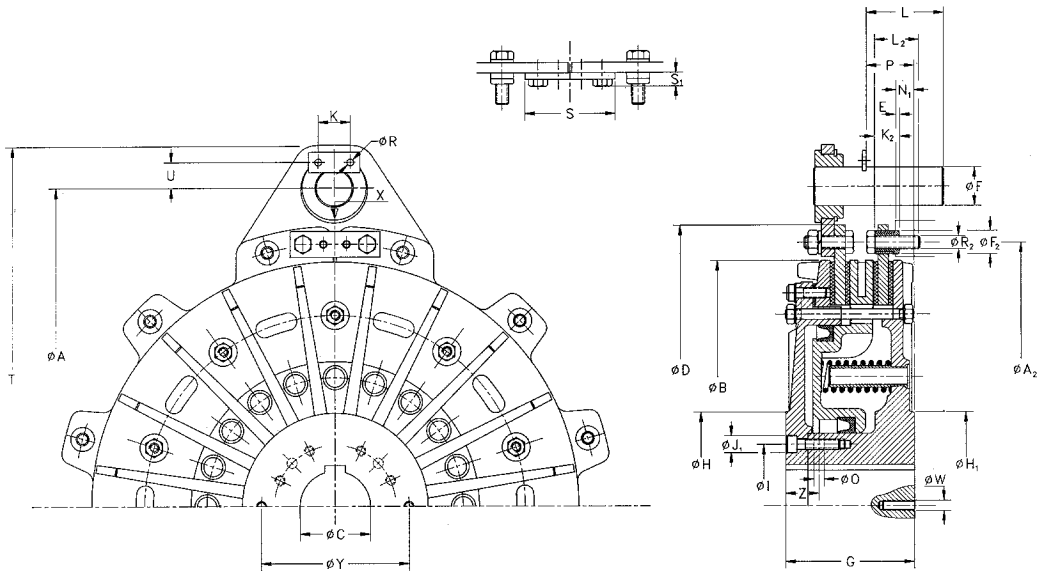

Serie 504..WD

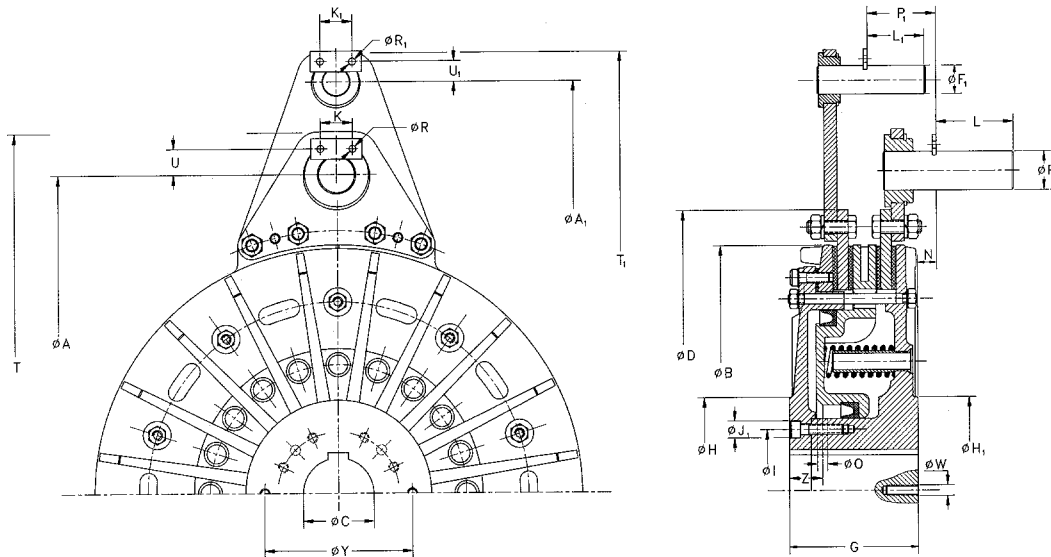

5

Size		60	10	18	36	55	75	76	77	78	79	
Clutch torque	Nm	600	1000	2100	4100	6200	8600	12600	17000	26000	45000	
Brake torque		400	650	1400	2900	4200	5300	8400	11000	16500	23000	
Pressure	bar	5,5										
Max speed	min ⁻¹	2300	1750	1450	1200	1000	900	800	760	600	450	
Weight	Kg	501	16	24	43	79	122	175	238	324	537	850
		502	15	23	41	77	117	163	229	312	515	-
		504	16	24	43	79	122	175	238	324	537	-
J	Kg m ²	Int	0,08	0,19	0,46	1,23	2,73	4,55	7,37	13,25	29,88	62
		501	0,043	0,114	0,274	0,768	1,354	2,144	4,57	7,51	16,78	32
		Ext	0,027	0,062	0,202	0,53	1,044	1,555	3,342	6,51	12,6	-
		502	0,043	0,114	0,274	0,768	1,354	2,144	4,57	7,51	16,78	-
504												
New vol	dm ³	0,136	0,23	0,482	0,797	1,15	1,47	2,25	2,83	5,37	7,3	
Max. wear vol.		0,255	0,385	0,792	1,37	1,9	2,44	3,86	4,98	8,7	11	
Ø A		345	390	495	610	695	770	880	970	1140	1300	
		440	490	635	790	885	990	1135	1235	1450	-	
		283	325	408	500	584	640	725	810	945	1080	
		265	305	380	466	542	599	675	755	885	1000	
Ø C	Min	32	35	45	50	60	60	75	90	115	140	
	Max	52	65	80	108	114	125	145	160	180	220	
Ø D		305	347	435	535	620	680	775	865	1000	1145	
		2	3	3	3	5	5	5	5	5	-	
Ø F		22	22	30	40	40	45	55	55	65	75	
		14	14	22	30	30	40	45	45	55	-	
		12	15	18	25	25	30	35	40	42	-	
G		72	82	100	125	145	160	185	203	255	295	
Ø H		105	125	145	190	206	225	265	276	300(330)	376	
		110	130	145	180	200	220	265	276	300	376	
Ø I		66	82	95	123	136	150	168	186	212	290	
		10,5	10,5	13,5	13,5	16,5	16,5	18,5	22,5	28	32	
K		25	25	25	35	35	35	45	45	45	60	
		20	20	25	25	25	35	35	35	45	-	
		14	17	19	25	30	32	36	40	48	-	
L		45	45	60	80	80	90	110	110	130	150	
		28	28	45	60	60	80	90	90	110	-	
		25	30	35	45	50	60	70	80	90	-	
M		1	1	3	4	4	8	8	14	20	57,5	
N		10	12,5	15	15	15	17,5	20	20	20	16,5	
		12	14	14,5	17	19	20	22	25	33	-	
Ø O	2 x 180°	8	10	12	14	16	16	20	20	28	32	
		27	27	39	58	61	58	83	94	114	-	
		39	46,5	53	74	86	84	103	115	147	-	
Ø R	12 x 30°	5,5	5,5	5,5	6,5	6,5	6,5	8,5	8,5	8,5	10,5	
		4,5	4,5	5,5	5,5	5,5	6,5	6,5	6,5	8,5	-	
		M6	M8	M10	M14	M14	M16	M20	M24	M24	-	
S		46	56	70	75	84	96	110	120	138	-	
		6,5	9,5	10,5	13,5	17	17	20	21	24	-	
T		390	435	560	695	780	870	1000	1090	1285	1460	
		475	527	680	855	950	1075	1235	1335	1570	-	
U		16	16	20	27	27	29,5	38,5	38,5	43,5	51	
		11	11	16	20	20	27	29,5	29,5	38,5	-	
W		M8	M8	M8	M10	M12	M12	M14	M16	M18	-	
		66	82	115	145	160	170	210	220	250	-	
		20	21	26	31	36,5	41	48	53	67	76	